

DP5 SERIES DPH SERIES

Related Information	■ General terms and conditions P.1	■ Sensor selection guide P.11~ / P.561~
	■ Glossary of terms P.948~	■ General precautions P.952

- FIBER SENSORS
- LASER SENSORS
- PHOTOELECTRIC SENSORS
- MICRO PHOTOELECTRIC SENSORS
- AREA SENSORS
- SAFETY COMPONENTS
- PRESSURE SENSORS**
- INDUCTIVE PROXIMITY SENSORS
- PARTICULAR USE SENSORS
- SENSOR OPTIONS
- WIRE-SAVING SYSTEMS
- MEASUREMENT SENSORS
- STATIC CONTROL DEVICES
- LASER MARKERS

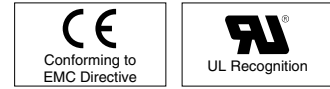

High speed response of 1/1,000 sec.

High speed response 1 ms

Mounting the detachable head close to the detecting section minimizes piping and enables response time of 1 ms, as well as greatly decreasing tact time delay. In addition, the ultra-small and light-weight design of the head means it can easily be mounted on moving sections.

Independent use of sensor head possible

Data can be controlled by taking the analog voltage output (1 to 5 V) from the sensor head and feeding it to a digital panel meter.

Sensor head with operation indicator

The sensor head is also equipped with operation indicator. Output ON / OFF can be checked on the sensor head, so that it is suitable for checking operation at the suction head. (Linked to Comparative Output 1)



Convenient intermediate cable with connector

Intermediate cable with connector for connecting the sensor head and the controller makes operation and maintenance easier.

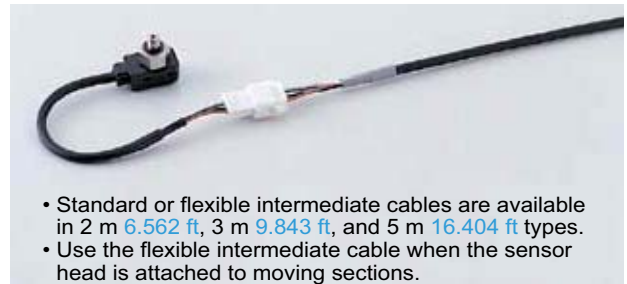

- Standard or flexible intermediate cables are available in 2 m 6.562 ft, 3 m 9.843 ft, and 5 m 16.404 ft types.
- Use the flexible intermediate cable when the sensor head is attached to moving sections.

A total of 10 head variations

A total of 10 head variations to meet all production demands.



Vacuum pressure type (0 to -101.3 kPa)

- M5 male thread
- R (PT) 1/8 male thread / M5 female thread
- NPT 1/8 male thread / 10-32UNF female thread
- 10-32UNF male thread

Positive pressure type (0 to 1.000 MPa)

- M5 female thread
- R (PT) 1/8 male thread / M5 female thread
- NPT 1/8 male thread / 10-32UNF female thread

Compound pressure type (-100.0 to 100.0 kPa)

- M5 female thread
- R (PT) 1/8 male thread / M5 female thread
- NPT 1/8 male thread / 10-32UNF female thread

BASIC PERFORMANCE

Globally usable

Two types of output, NPN and PNP, are available to allow use of the sensors anywhere in the world. The sensor, of course, conforms to the CE marking EMC Directive. Further, it has obtained UL Recognition.



MOUNTING / SIZE

Easy mounting, mobile pressure port

The head's pressure port can be rotated independently (free-turning) of the sensor head. In addition to being easy to mount, the cable can be laid in any direction.



Light-weight, compact design

The controller was designed to be light-weight and compact. Control panel setup is low cost and requires minimal space.

Supplied with a panel mounting bracket

A panel mounting bracket (**MS-DP-1**) is enclosed to enable simple mounting of the controller onto the panel surface, thus contributing to the total cost reduction. Since the panel thickness can be from 1 to 6 mm **0.039 to 0.236 in**, the controller can even be mounted on thick, resin-made panels. The attached panel mounting bracket enables vertical installation.



FUNCTIONS

User friendly two-color digital display

The user friendly two-color digital display changes color when output changes (ON / OFF), making it easy to check operation status at a glance. The display color can be linked to Comparative Output 1 or Comparative Output 2.

Two independent outputs plus analog voltage output

In addition to two independent outputs (ON / OFF), analog voltage output (1 to 5 V) is also available. The different outputs allow you to create solutions for a wide variety of applications.

OPTIONS

2 types of sensor mounting brackets are available

Using the vertical mounting bracket (**MS-DP-3**) and the horizontal mounting bracket (**MS-DP-4**), the devices can be installed in the space inside machines or boxes.

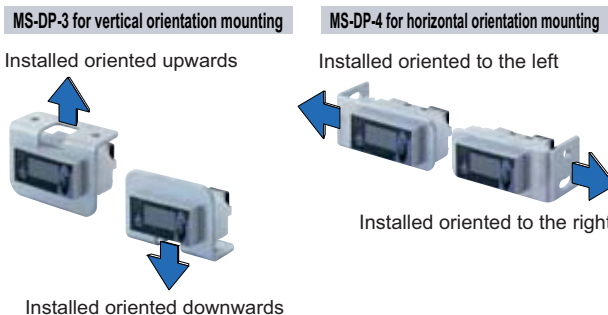

DIN rail mounting bracket is available

The controller can be mounted even on a 35 mm **1.378 in** width DIN rail by using the optional DIN rail mounting bracket (**MS-DP-2**). It can be fitted even in a narrow space inside your equipment because it can be mounted from four directions.



Made for horizontal panel mounting

Using the horizontal multiple panel mounting bracket, the **MS-DP-5** (optional), direct panel surface horizontal mounting is rendered possible. For installation, the panel thickness must be from 1 to 6 mm **0.039 to 0.236 in**.

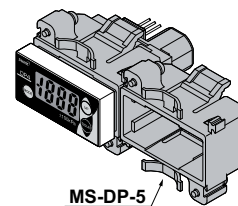

Two operation indicators

There are two operation indicators that light respectively when Comparative Output 1 or Comparative Output 2 is ON. They are convenient for intensive operation checks.

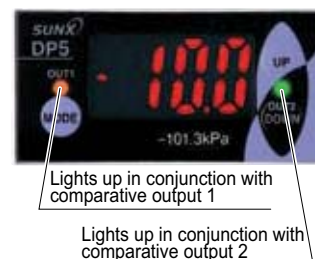

Sensor head auto-recognition

The head's auto-recognition function means you don't have to manually set the head type at the controller, saving you valuable time.

- FIBER SENSORS
- LASER SENSORS
- PHOTOELECTRIC SENSORS
- MICRO PHOTOELECTRIC SENSORS
- AREA SENSORS
- SAFETY COMPONENTS
- PRESSURE SENSORS
- INDUCTIVE PROXIMITY SENSORS
- PARTICULAR USE SENSORS
- SENSOR OPTIONS
- WIRE-SAVING SYSTEMS
- MEASUREMENT SENSORS
- STATIC CONTROL DEVICES
- LASER MARKERS

- Selection Guide
- Flow
- FM-200**
- Digital Display
- DP-100**
- DP4**
- DP-M**
- Head-separated
- DPH-100**
- DPC-100**
- DP5 / DPH**
- Other Products

- FIBER SENSORS
- LASER SENSORS
- PHOTOELECTRIC SENSORS
- MICRO PHOTOELECTRIC SENSORS
- AREA SENSORS
- SAFETY COMPONENTS
- PRESSURE SENSORS**
- INDUCTIVE PROXIMITY SENSORS
- PARTICULAR USE SENSORS
- SENSOR OPTIONS
- WIRE-SAVING SYSTEMS
- MEASUREMENT SENSORS
- STATIC CONTROL DEVICES
- LASER MARKERS
- Selection Guide
- Flow
- FM-200**
- Digital Display
- DP-100**
- DP4**
- DP-M**
- Head-separated
- DPH-100**
- DPH-100**
- DP5 / DPH**
- Other Products

FUNCTIONS

Able to handle a wide variety of applications through its four output modes

Leak test mode

It is suitable for a leak test since Comparative Output 1 can be set to the hysteresis mode and Comparative Output 2 can be set to the window comparator mode. Using it along with the external input function the auto-reference / remote zero-adjustment functions ensures a reliable leak test.

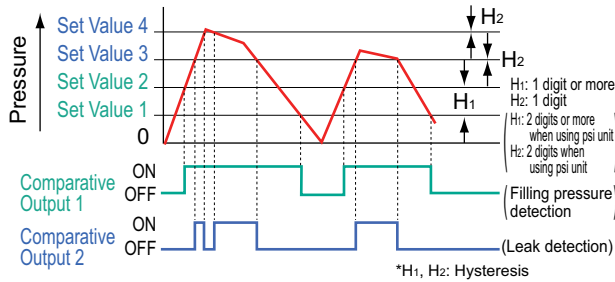

Window comparator mode

The comparative output can be turned ON or OFF by a pressure which is within the set pressure range.

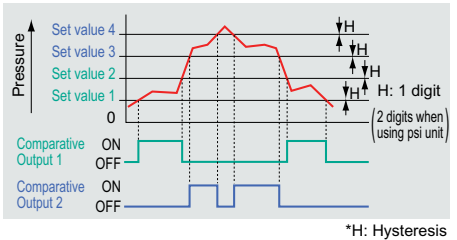

Forced output mode

The comparative outputs are forcibly maintained at OFF level in the sensing mode, irrespective of the set values. Hence, it is convenient for only displaying the pressure value without using the comparative outputs. Further, since the comparative outputs can be forcibly switched ON or OFF with key operation, without actually applying pressure, this mode is suitable for an operation check or a start-up check.

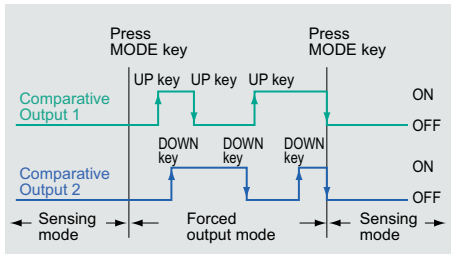

Hysteresis mode

The hysteresis of the comparative outputs can be set arbitrarily by the set values for ON / OFF control.

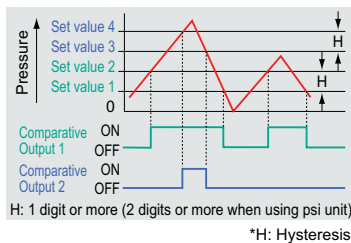

Equipped with external input function (auto-reference and remote zero-adjustment functions)

If the reference pressure of the equipment changes, the auto-reference function can compensate the threshold levels by the amount of change and the remote zero-adjustment function can reset the display value to zero via external input. These functions are ideal for places where the reference pressure fluctuates wildly, or where fine settings are desired. The external input functions can be selected with the supplementary setting mode using key operations.

Example: When leak test mode is applied, Comparative Output 1 detects the filling pressure and Comparative Output 2 detects the leakage.

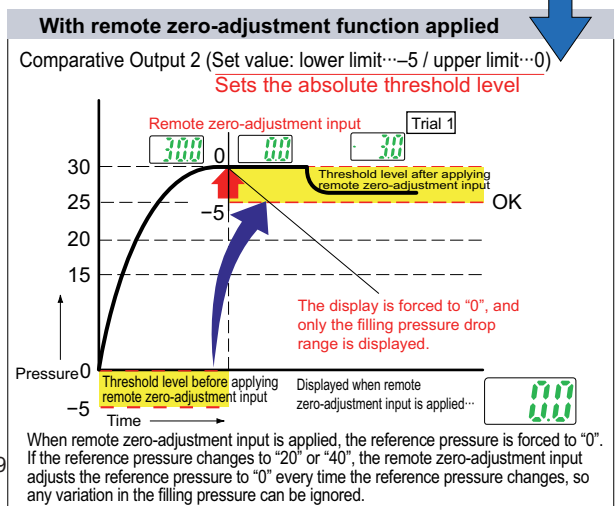
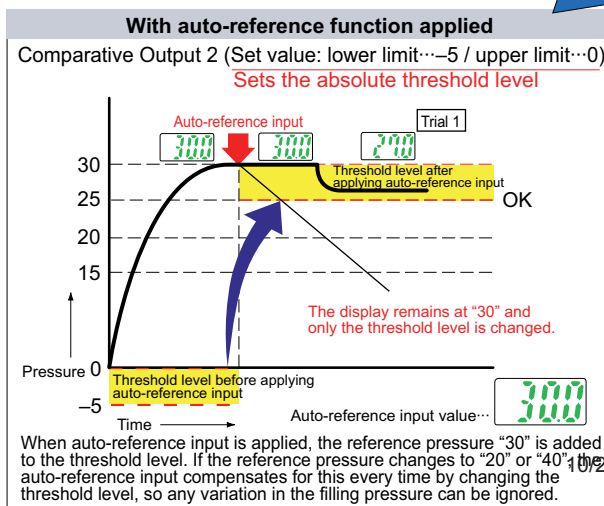
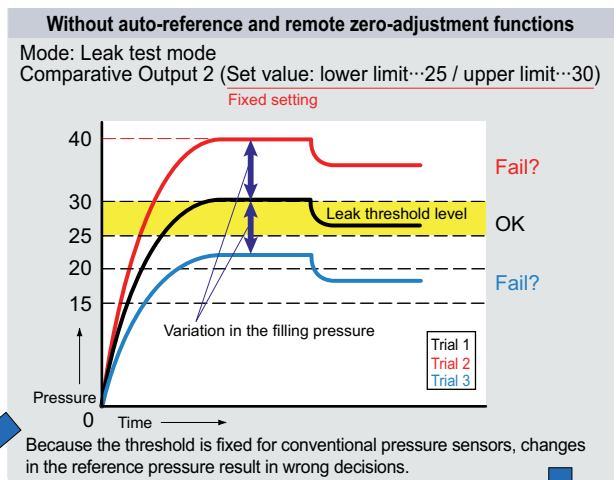

ORDER GUIDE

DP5 / DPH configuration diagram

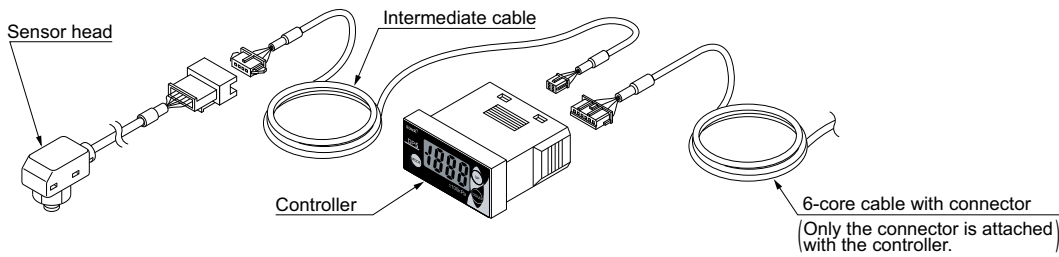

Sensor head An intermediate cable is required to connect the controller and the sensor head. Please order it separately.

Type	Appearance	Rated pressure range (Note)	Model No.	Pressure port	Applicable fluid	
Vacuum pressure		0 to -101.3 kPa	DPH-A00	M5 male thread	Non-corrosive gas	
				DPH-A10		R (PT) 1/8 male thread / M5 female thread
				DPH-A20		NPT 1/8 male thread / 10-32UNF female thread
Positive pressure		0 to 1.000 MPa	DPH-A02	M5 male thread		
				DPH-A12		R (PT) 1/8 male thread / M5 female thread
				DPH-A22		NPT 1/8 male thread / 10-32UNF female thread
Compound pressure		-100.0 to 100.0 kPa	DPH-A07	M5 male thread		
				DPH-A17		R (PT) 1/8 male thread / M5 female thread
				DPH-A27		NPT 1/8 male thread / 10-32UNF female thread

Note: The rated pressure range indicates the range for full product performance.

Controller An intermediate cable is required to connect the controller and the sensor head. Please order it separately.

Appearance	Rated pressure range (Note)	Model No.	Output
	Vacuum pressure: 0 to -101.3 kPa Positive pressure: 0 to 1.000 MPa Compound pressure: -100.0 to 100.0 kPa	DP5-C	NPN open-collector transistor
		DP5-C-P	PNP open-collector transistor

Note: The rated pressure range indicates the range for full product performance. It changes automatically according to the connected pressure sensor head.

Intermediate cable An intermediate cable is required to connect the controller and the sensor head. Please order it separately.

Designation	Appearance	Model No.	Description
Standard		DPH-CC2	Length: 2 m 6.562 ft
		DPH-CC3	Length: 3 m 9.843 ft
		DPH-CC5	Length: 5 m 16.404 ft
Flexible		DPH-CC2-R	Length: 2 m 6.562 ft
		DPH-CC3-R	Length: 3 m 9.843 ft
		DPH-CC5-R	Length: 5 m 16.404 ft

Accessory

- MS-DP-1 (Panel mounting bracket)

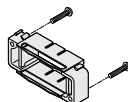

FIBER SENSORS

LASER SENSORS

PHOTO-ELECTRIC SENSORS

MICRO PHOTO-ELECTRIC SENSORS

AREA SENSORS

SAFETY COMPONENTS

PRESSURE SENSORS

INDUCTIVE PROXIMITY SENSORS

PARTICULAR USE SENSORS

SENSOR OPTIONS

WIRE-SAVING SYSTEMS

MEASUREMENT SENSORS

STATIC CONTROL DEVICES

LASER MARKERS

Selection Guide

Flow

FM-200

Digital Display

DP-100

DP4

DP-M

Head-separated

DPH-100

DPC-100

DP5 / DPH

Other Products

- FIBER SENSORS
- LASER SENSORS
- PHOTO-ELECTRIC SENSORS
- MICRO PHOTO-ELECTRIC SENSORS
- AREA SENSORS
- SAFETY COMPONENTS
- PRESSURE SENSORS**
- INDUCTIVE PROXIMITY SENSORS
- PARTICULAR USE SENSORS
- SENSOR OPTIONS
- WIRE-SAVING SYSTEMS
- MEASUREMENT SENSORS
- STATIC CONTROL DEVICES
- LASER MARKERS
- Selection Guide
- Flow
- FM-200**
- Digital Display
- DP-100**
- DP4**
- DP-M**
- Head-separated
- DPH-100**
- DPC-100**
- DP5 / DPH**
- Other Products

OPTIONS

Designation	Model No.	Description	
Connector	CN-66	Set of 10 housings and 60 connector pins	
6-core cable with connector	CN-66-C2	Length: 2 m 6.562 ft	0.2 mm ² 6-core cabtyre cable with connector Cable outer diameter: \varnothing 4.8 mm \varnothing0.189 in
	CN-66-C5	Length: 5 m 16.404 ft	
DIN rail mounting bracket	MS-DP-2	For installation to 35 mm 1.378 in width DIN rail	
Controller mounting bracket	MS-DP-3	Vertical mounting bracket	
	MS-DP-4	Horizontal mounting bracket	
Horizontal multiple panel mounting bracket	MS-DP-5	Enables the sensors to be attached to each other laterally and mounted on the panel.	

Connector

- **CN-66**

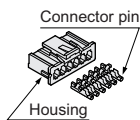

6-core cable with connector

- **CN-66-C2**
- **CN-66-C5**

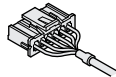

DIN rail mounting bracket

- **MS-DP-2**

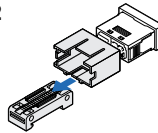

Controller mounting bracket

- **MS-DP-3**

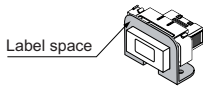

- **MS-DP-4**



Horizontal multiple panel mounting bracket

- **MS-DP-5**

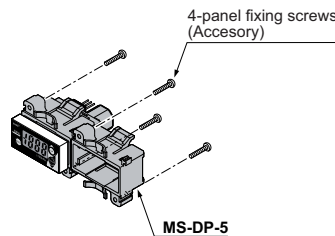

Designed with a 9 mm **0.354 in** label space to enable the labeling of the sensors with a label printer (9 mm **0.354 in** width) for sensor number and application data.

* The above illustration shows two units connected in sequence.

SPECIFICATIONS

Sensor head

Item	Type Model No.	Vacuum pressure				Positive pressure			Compound pressure		
		-101 kPa type				1 MPa type			±100 kPa type		
		DPH-A00	DPH-A10	DPH-A20	DPH-A30	DPH-A02	DPH-A12	DPH-A22	DPH-A07	DPH-A17	DPH-A27
Type of pressure		Gauge pressure									
Rated pressure range (Note 2)		0 to -101.3 kPa				0 to 1.000 MPa			-100.0 to 100.0 kPa		
Pressure withstandability		500 kPa				1.500 MPa			500 kPa		
Applicable fluid		Non-corrosive gas									
Supply voltage		12 to 24 V DC $\begin{matrix} +10 \\ -15 \end{matrix}$ % Ripple P-P 10 % or less									
Current consumption		15 mA or less (operation indicator lights off) / 17 mA or less (operation indicator lights on)									
Analog voltage output		Output voltage: 1 to 5 V (over rated pressure range) Zero point: within 1 V ±2 % F.S. (vacuum / positive pressure type) within 3 V ±3 % F.S. (compound pressure type) Span: within 4 V ±3.5 % F.S. Linearity: within ±1 % F.S. Output impedance: 1 kΩ approx. Output current: 10 μA									
Environmental resistance	Pollution degree	3 (Industrial environment)									
	Protection	IP40 (IEC) (Refer to p.1001 for details of standards.)									
	Ambient temperature	0 to +50 °C +32 to +122 °F (No dew condensation), Storage: -10 to +60 °C +14 to +140 °F									
	Ambient humidity	35 to 85 % RH, Storage: 35 to 85 % RH									
	EMC	EN 61000-6-2, EN61000-6-4									
	Voltage withstandability	1,000 V AC for one min. between all supply terminals connected together and enclosure									
	Insulation resistance	50 MΩ, or more, with 500 V DC megger between all supply terminals connected together and enclosure									
	Vibration resistance	10 to 500 Hz frequency, 3 mm 0.118 in amplitude, in X, Y and Z directions for two hours each									
Shock resistance	1,000 m/s ² acceleration (100 G approx.) in X, Y and Z directions for three times each										
Operation indicator		Orange LED [lights up when the Comparative Output 1 is ON (only in case of connection to the DP5 series pressure controller)]									
Temperature characteristics		Over ambient temperature range +10 to +40 °C +50 to +104 °F : within ±1 % F.S. of detected pressure at +25 °C +77 °F Over ambient temperature range 0 to +50 °C +32 to +122 °F : within ±3 % F.S. of detected pressure at +25 °C +77 °F									
Voltage characteristics		Within ±0.5 % F.S. for ±10 % fluctuation of the supply voltage									
Pressure port		DPH-A0 □: M5 male thread (for installing gasket), DPH-A1 □: R (PT) 1/8 male thread / M5 female thread DPH-A2 □: NPT 1/8 male thread / 10-32UNF female thread, DPH-A30 : 10-32UNF male thread (for installing gasket)									
Material		Enclosure: PBT, Pressure port: Brass (nickel plated) [however, stainless steel (SUS303) in case of DPH-A0 □]									
Connecting method		Connector									
Cable		0.2 mm ² 4-core oil resistant cabtyre cable with connector, 100 mm 3.937 in long									
Cable extension		Extension up to total 10 m 32.808 ft is possible with 0.3 mm ² , or more, cable.									
Net weight		DPH-A0 □ / DPH-A30 : 6 g approx., DPH-A1 □ / DPH-A2 □: 10 g approx.									
Accessories		Gasket (DPH-A0 □, DPH-A30 only)									

- Notes: 1) Where measurement conditions have not been specified precisely, the conditions used were an ambient temperature of +20 °C **+68 °F**.
2) The rated pressure range indicates the range for full product performance.
3) The sensor head can be used independently.

FIBER
SENSORSLASER
SENSORSPHOTO-
ELECTRIC
SENSORSMICRO
PHOTO-
ELECTRIC
SENSORSAREA
SENSORSSAFETY
COMPONENTSPRESSURE
SENSORSINDUCTIVE
PROXIMITY
SENSORSPARTICULAR
USE
SENSORSSENSOR
OPTIONSWIRE-
SAVING
SYSTEMSMEASURE-
MENT
SENSORSSTATIC
CONTROL
DEVICESLASER
MARKERSSelection
Guide

Flow

FM-200Digital
Display**DP-100****DP4****DP-M**Head-
separated**DPH-100****DPC-100****DP5 / DPH**Other
Products

SPECIFICATIONS

Controller

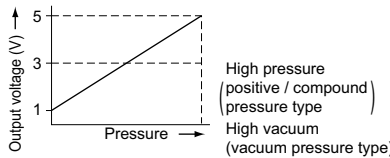
Item	Type	NPN output type		PNP output type	
	Model No.	DP5-C		DP5-C-P	
Applicable sensor head	DPH-A00, DPH-A02, DPH-A07, DPH-A10, DPH-A12, DPH-A17, DPH-A20, DPH-A22, DPH-A27, DPH-A30				
Rated pressure range (Note 2)	Vacuum pressure: 0 to -101.3 kPa, Positive pressure: 0 to 1.000 MPa, Compound pressure: -100.0 to 100.0 kPa				
Set pressure range (Note 2)	Vacuum pressure: 101.3 to -101.3 kPa (1.033 to -1.033 kgf/cm ² , 14.70 to -14.70 psi, 1.013 to -1.013 bar, 760 to -760 mmHg, 29.9 to -29.9 inHg) Positive pressure: -1.050 to 1.050 MPa (-10.71 to 10.71 kgf/cm ² , -152.2 to 152.2 psi, -10.50 to 10.50 bar) Compound pressure: -199.9 to 199.9 kPa (-1.999 to 1.999 kgf/cm ² , -19.98 to 19.98 psi, -1.999 to 1.999 bar, -1510 to 1537 mmHg, -59.4 to 60.5 inHg)				
Supply voltage / Current consumption	12 to 24 V DC ⁺¹⁰ / ₋₁₅ % Ripple P-P 10 % or less / 60 mA or less (not including sensor head)				
Sensor supply voltage	Same as supply voltage				
Comparative outputs (Comparative Output 1, 2)	NPN open-collector transistor (2 outputs)		PNP open-collector transistor (2 outputs)		
	<ul style="list-style-type: none"> • Maximum sink current: 100 mA • Applied voltage: 30 V DC or less (between comparative output and 0 V) • Residual voltage: 1 V or less (at 100 mA sink current) 0.4 V or less (at 16 mA sink current) 		<ul style="list-style-type: none"> • Maximum source current: 100 mA • Applied voltage: Same as supply voltage (between comparative output and +V) • Residual voltage: 2 V or less (at 100 mA source current) 		
Utilization category	DC-12 or DC-13				
Output operation	NO / NC, selectable by key operation				
Output modes	Equipped with 4 types of modes: hysteresis mode, window comparator mode, leak test mode, forced output mode (selectable by key operation)				
Hysteresis	1 digit (however, variable in hysteresis mode, variable for Comparative Output 1 only when using leak test mode)				
Repeatability	With vacuum / positive pressure type sensor head: within ±0.2 % F.S. ±1 digit (±3 digits) With compound pressure type sensor head: within ±0.2 % F.S. ±2 digits (±6 digits)				
Response time	1 ms, 16 ms, 128 ms, 512 ms or less, selectable by key operation (however, set response time is + 2 ms when auto-reference / remote zero-adjustment input is applied)				
Short-circuit protection	Incorporated				
Sensor head input	Input voltage range: 1 to 5 V DC (over rated pressure range)				
Inputs	External input (Auto-reference / Remote zero-adjustment function)	Input condition: NPN non-contact input [operates in Low (fall) state] Signal condition: High...5 to 30 V, or open Low...0.4 V or less Low level input time...2 ms or more		Input condition: PNP non-contact input [operates in High (rise) state] Signal condition: High...5 to 30 V Low...0.4 V or less, or open High level input time...2 ms or more	
	Analog voltage output	Output voltage: 1 to 5 V DC (over rated pressure range) Zero point: within 1 V ± 2.5 % F.S. (vacuum / positive pressure type) within 3 V ± 3.5 % F.S. (compound pressure type) Span: within 4 V ± 4 % F.S. Linearity: within ±1 % F.S. Output impedance: 1 kΩ approx.			
Display	3 1/2 digit LCD display (with red and green backlight) (Display refresh rate: 256 ms, 512 ms or 1,024 ms selectable by key operation)				
DP4	Displayable pressure range	Vacuum pressure: 5.1 to -101.3 kPa (0.052 to -1.033 kgf/cm ² , 0.74 to -14.70 psi, 0.051 to -1.013 bar, 38 to -760 mmHg, 1.5 to -29.9 inHg) Positive pressure: -0.050 to 1.050 MPa (-0.51 to 10.71 kgf/cm ² , -7.2 to 152.2 psi, -0.50 to 10.50 bar) Compound pressure: -101.3 to 105.0 kPa (-1.033 to 1.071 kgf/cm ² , -14.70 to 15.22 psi, -1.013 to 1.050 bar, -760 to 787 mmHg, -29.9 to 31.0 inHg)			
	Operation display	LCD segment is red when the comparative output is ON, and green when it is OFF (output is selected via supplementary settings)			
DP-M	Analog bar display	Bar display in steps of 14 % F.S. approx.			
DPH-100 DPC-100	Operation indicator	Orange LED (lights up when the Comparative Output 1 is ON), Green LED (lights up when the Comparative Output 2 is ON)			
DP5 / DPH Other Products	Environmental resistance	Pollution degree	3 (Industrial environment)		
		Protection	IP40 (IEC) (Refer to p.1001 for details of standards.)		
		Ambient temperature	0 to +50 °C +32 to +122 °F (No dew condensation), Storage: -10 to +60 °C +14 to +140 °F		
		Ambient humidity	35 to 85 % RH, Storage: 35 to 85 % RH		
		EMC	EN 61000-6-2, EN 61000-6-4		
		Voltage withstandability	1,000 V AC for one min. between all supply terminals connected together and enclosure		
		Insulation resistance	50 MΩ, or more, with 500 V DC megger between all supply terminals connected together and enclosure		
		Vibration resistance	10 to 150 Hz frequency, 0.75 mm 0.030 in amplitude, in X, Y and Z directions for two hours each		
Shock resistance	100 m/s ² acceleration (10 G approx.) in X, Y and Z directions for three times each				
Temperature characteristics	Over ambient temperature range 0 to +50 °C +32 to +122 °F: within ±0.5 % F.S. of detected pressure at +25 °C +77 °F (not including sensor head)				
Material	Front case: ABS, LCD display section: PET, Rear case: PBT				
Connecting method	Connector				
Suitable cable	Conductor cross-section area	0.16 to 0.32 mm ² (AWG#25 to #22) (Note 3)			
	Lead wire diameter	ø1.2 to ø1.8 mm ø0.047 to ø0.071 in			
	Wire material	Tin plated, soft, twisted copper wire			
Cable length	Total length up to 100 m 328.084 ft (less than 10 m 32.808 ft when conforming to CE marking) is possible with 0.3 mm ² , or more, cable.				
Weight	Net weight: 20 g approx.				
Accessories	Panel mounting bracket (MS-DP-1): 1 set, Connector: 1 set (Housing: 1 pc., Connector pin: 6 pcs.), Pressure unit label: 1 set., Connector cap: 1 pc.				

Notes: 1) Where measurement conditions have not been specified precisely, the conditions used were an ambient temperature of +20 °C +68 °F.

2) The rated pressure range indicates the range for full product performance. It changes automatically according to the connected pressure sensor head.

3) If the wiring is longer than 5 m 16.404 ft, use a cable with a diameter of 0.3 mm² or more.

I/O CIRCUIT DIAGRAMS

DP5-C

NPN output type

I/O circuit diagram

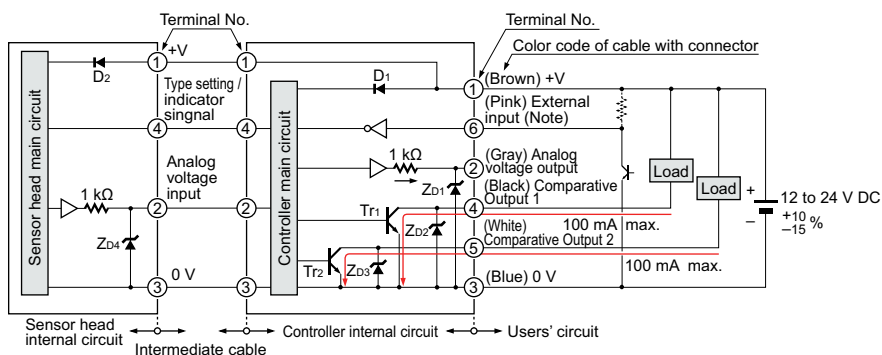

Note: Select and use the auto-reference function and remote zero-adjustment function.

Symbols ... D1, D2: Reverse supply polarity protection diode
 ZD1 to ZD4: Surge absorption zener diode
 Tr1, Tr2: NPN output transistor

Terminal arrangement diagram

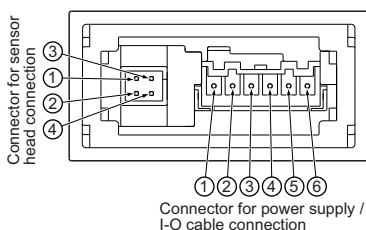

Connector for power supply / I-O cable connection

- ① +V
- ② Analog voltage output
- ③ 0 V
- ④ Comparative Output 1
- ⑤ Comparative Output 2
- ⑥ External input (Auto-reference / Remote zero-adjustment function)

For independent use of Sensor head

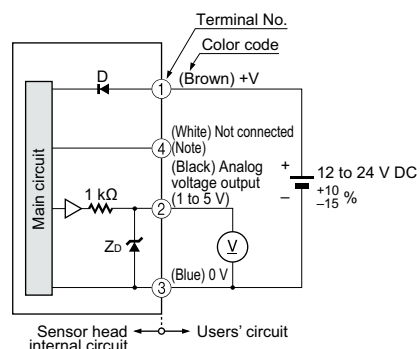

Note: In case the sensor head is used independently, insulate the white lead wire (terminal No.4) and keep it open.

Symbols ... D : Reverse supply polarity protection diode
 ZD: Surge absorption zener diode

Connector for sensor head connection

- ① +V
- ② Analog voltage output
- ③ 0 V
- ④ Not connected

DP5-C-P

PNP output type

I/O circuit diagram

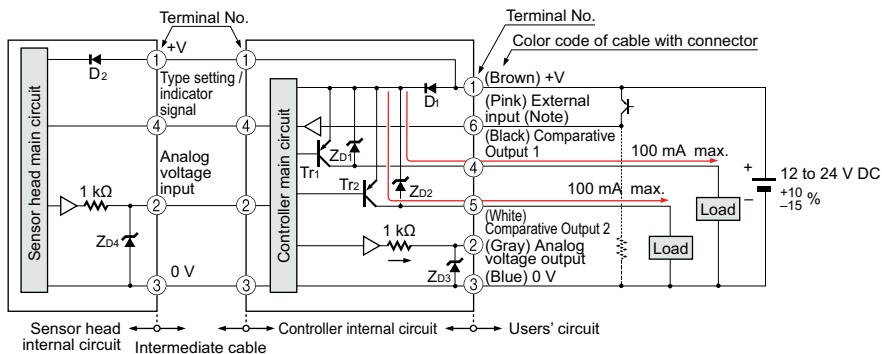

Note: Select and use the auto-reference function and remote zero-adjustment function.

Symbols ... D1, D2: Reverse supply polarity protection diode
 ZD1 to ZD4: Surge absorption zener diode
 Tr1, Tr2: PNP output transistor

Terminal arrangement diagram

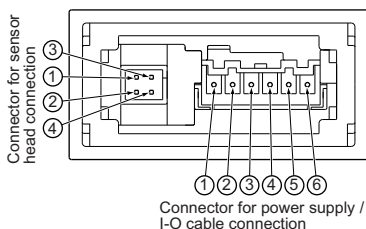

Connector for power supply / I-O cable connection

- ① +V
- ② Analog voltage output
- ③ 0 V
- ④ Comparative Output 1
- ⑤ Comparative Output 2
- ⑥ External input (Auto-reference / Remote zero-adjustment function)

For independent use of Sensor head

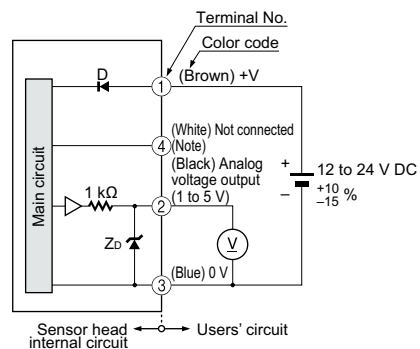

Note: In case the sensor head is used independently, insulate the white lead wire (terminal No.4) and keep it open.

Symbols ... D: Reverse supply polarity protection diode
 ZD: Surge absorption zener diode

Connector for sensor head connection

- ① +V
- ② Analog voltage output
- ③ 0 V
- ④ Not connected

FIBER SENSORS

LASER SENSORS

PHOTO-ELECTRIC SENSORS

MICRO PHOTO-ELECTRIC SENSORS

AREA SENSORS

SAFETY COMPONENTS

PRESSURE SENSORS

INDUCTIVE PROXIMITY SENSORS

PARTICULAR USE SENSORS

SENSOR OPTIONS

WIRE- SAVING SYSTEMS

MEASURE- MENT SENSORS

STATIC CONTROL DEVICES

LASER MARKERS

Selection Guide

Flow

FM-200

Digital Display

DP-100

DP4

DP-M

Head-separated

DPH-100

DP5 / DPH

Other Products

- FIBER SENSORS
- LASER SENSORS
- PHOTO-ELECTRIC SENSORS
- MICRO PHOTO-ELECTRIC SENSORS
- AREA SENSORS
- SAFETY COMPONENTS
- PRESSURE SENSORS**
- INDUCTIVE PROXIMITY SENSORS
- PARTICULAR USE SENSORS
- SENSOR OPTIONS
- WIRE-SAVING SYSTEMS
- MEASUREMENT SENSORS
- STATIC CONTROL DEVICES
- LASER MARKERS
- Selection Guide
- Flow
- FM-200**
- Digital Display
- DP-100**
- DP4**
- DP-M**
- Head-separated
- DPH-100**
- DPC-100**
- DP5 / DPH**
- Other Products

PRECAUTIONS FOR PROPER USE

Refer to p.952 for general precautions.



- Never use this product as a sensing device for personnel protection.
- In case of using sensing devices for personnel protection, use products which meet laws and standards, such as OSHA, ANSI or IEC etc., for personnel protection applicable in each region or country.
- The DPH series is designed for use with non-corrosive gas. It cannot be used with liquid or corrosive gas.

Operation

- If setting is impossible even with pressing the MODE key, verify whether the key-protect function is enabled. Please note that pressing down on the MODE key for an extended moment will enable the key-protect function as soon as the key is released.
- If using the window comparator mode, set the pressure values so that there is a difference of 3 digits, or more, between Set Value 1 (P-1) and Set Value 2 (P-2) and between Set Value 3 (P-3) and Set Value 4 (P-4). The output does not operate if the interval is between 0 and 2 digits.

Functional description

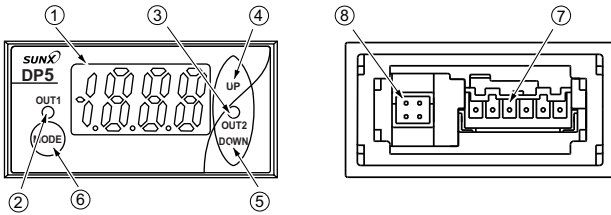

	Description	Function
①	3 1/2 digit LCD display (with red and green backlight)	<ul style="list-style-type: none"> • Displays measured pressure, settings, error messages and key-protect status. • Its lighting up can be set as Red when ON / Green when OFF with respect to either Comparative Output 1 or Comparative Output 2, according to the backlight relation selection during the supplementary setting mode.
②	Comparative Output 1 operation indicator (Orange)	<ul style="list-style-type: none"> • Lights up when Comparative Output 1 is ON.
③	Comparative Output 2 operation indicator (Green)	<ul style="list-style-type: none"> • Lights up when Comparative Output 2 is ON.
④	Increment (UP) key	<ul style="list-style-type: none"> • In the initial setting mode and supplementary setting mode, pressing the key changes the setting item. • In the pressure value setting mode, pressing the key changes the set value. • In the sensing mode, pressing the key continuously for 4 sec., or more, displays the peak hold value.
⑤	Decrement (DOWN) key	<ul style="list-style-type: none"> • In the initial setting mode and supplementary setting mode, pressing the key changes the set conditions. • In the pressure value setting mode, pressing the key changes the set value. • In the sensing mode, pressing the key continuously for 4 sec., or more, displays the bottom hold value.
⑥	MODE key	<ul style="list-style-type: none"> • In the pressure value setting mode, pressing the key changes the setting item. • In the sensing mode, pressing the key continuously for 4 sec., or more, can set / cancel the key-protect. • In the sensing mode, pressing both UP key and MODE key simultaneously changes the mode to the initial setting mode. Whereas, pressing both DOWN key and MODE key simultaneously changes the mode to the supplementary setting mode.
⑦	Connector for power supply / I-O cable connection	<ul style="list-style-type: none"> • It is the connector for connection of power supply / I-O cable.
⑧	Connector for sensor head connection	<ul style="list-style-type: none"> • It is the connector for connection of sensor head.

In the sensing mode, if both keys are simultaneously pressed continuously, zero-point adjustment is done.

Wiring

- Make sure that the power supply is off while wiring.
- Verify that the supply voltage variation is within the rating.
- If power is supplied from a commercial switching regulator, ensure that the frame ground (F.G.) terminal of the power supply is connected to an actual ground.
- In case noise generating equipment (switching regulator, inverter motor, etc.) is used in the vicinity of this controller, connect the frame ground (F.G.) terminal of the equipment to an actual ground.
- If the used power supply generates a surge, connect a surge absorber to the power supply to absorb the surge.
- Do not run the wires together with high-voltage lines or power lines or put them in the same raceway. This can cause malfunction due to induction.
- In order to reduce noise, make the wiring as short as possible.
- Take care that wrong wiring will damage the sensor.

Conditions in use for CE conformity

- The controller is a CE conformity product complying with EMC Directive. The harmonized standard with regard to immunity that applies to this product is EN 61000-6-2 and the following condition must be met to conform to that standard.

Conditions

- The controller should be connected less than 10 m / 32.808 ft from the power supply.
- The signal line to connect with the controller should be less than 30 m / 98.425 ft.

Setting

- The set conditions are written and stored into an EEPROM. However, note that the EEPROM has a life span and its guaranteed life is 100,000 write operation cycles. Further, since the Set Value P-A is not stored in the EEPROM, they are not included in the number of write operation cycles.

PRECAUTIONS FOR PROPER USE

Refer to p.952 for general precautions.

Auto-reference function

- Auto-reference function corrects Set Value P-3 and Set Value P-4 of Comparative Output 2 by taking the pressure measured at the time of auto-reference input as the reference pressure. Please select the auto-reference function at the supplementary setting mode when using this function.

<Before auto-reference input>

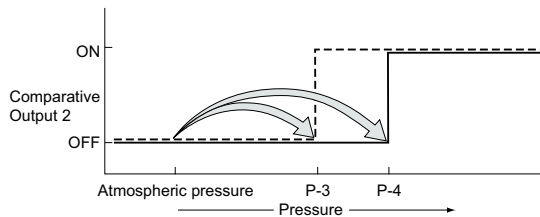

- When there is no auto-reference input, the atmospheric pressure is taken as the reference pressure for Set Value P-3 and Set Value P-4.

<After auto-reference input>

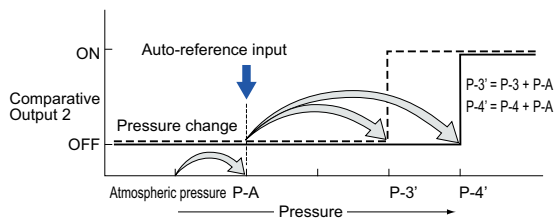

- At the time of auto-reference input, the pressure value detected at that instant is temporarily recorded as Set Value P-A and becomes the reference pressure.
- With Set Value P-A as the reference pressure, Set Value P-3 and Set Value P-4 are automatically corrected to "Set Value P-3 + Set Value P-A" and "Set Value P-4 + Set Value P-A", respectively.

Settable range and set pressure range after correction

- The settable range of Set Value P-3 and Set Value P-4 is wider than the rated pressure range to cater to the auto-reference function.

At the time of auto-reference input, if the corrected set value exceeds the set pressure range, the set value is automatically corrected to be within the set pressure range. Hence, please see that the set pressure range is not exceeded.

Operation chart

<Normal operation (comparative outputs set to NO)>

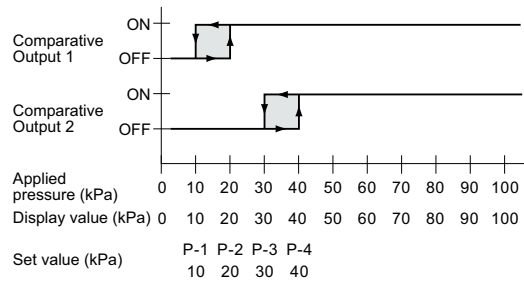

<With auto-reference input (comparative outputs set to NO)>

Auto-reference input: 50 kPa
Output mode: Hysteresis mode

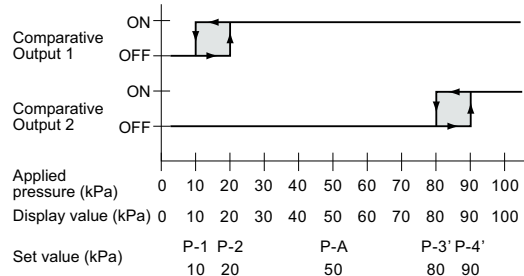

Note: As in the case of the hysteresis mode, Set Value P-3 and Set Value P-4 are shifted also in case the output is set to the window comparator mode or the leak test mode.

- Maintain the pressure at a constant level for at least 2 ms after the auto-reference input is made Low (High in case of PNP output type). If used in a transient state, it will result in wrong operation.
- Use Comparative Output 2 at least "set response time + 2 ms" after the auto-reference input is made Low (High in case of PNP output type).
- At the time of auto-reference input, is displayed on the 3 1/2 digit display for 1 sec. approx.
- The auto-reference input value (Set Value P-A) becomes zero when the power supply is switched off and then on again.
- Although it is not possible to display the corrected Set Value P-3' and Set Value P-4', it is possible to display the auto-reference input value (Set Value P-A).

- FIBER SENSORS
- LASER SENSORS
- PHOTO-ELECTRIC SENSORS
- MICRO PHOTO-ELECTRIC SENSORS
- AREA SENSORS
- SAFETY COMPONENTS
- PRESSURE SENSORS**
- INDUCTIVE PROXIMITY SENSORS
- PARTICULAR USE SENSORS
- SENSOR OPTIONS
- WIRE-SAVING SYSTEMS
- MEASUREMENT SENSORS
- STATIC CONTROL DEVICES
- LASER MARKERS
- Selection Guide
- Flow
- FM-200**
- Digital Display
- DP-100**
- DP4**
- DP-M**
- Head-separated
- DPH-100
- DPC-100
- DP5 / DPH**
- Other Products

PRECAUTIONS FOR PROPER USE

Refer to p.952 for general precautions.

Remote zero-adjustment function

- The remote zero-adjustment function forcibly displays the pressure value at the time of application of an external input signal to zero. Please select the remote zero-adjustment function at the supplementary setting mode when using this function.

• At the time of remote zero-adjustment input, the set values are not corrected. When using the remote zero-adjustment function, make sure that the pressure and the set values do not exceed the rated pressure range.

Operation chart

<Normal operation (comparative outputs set to NO)>

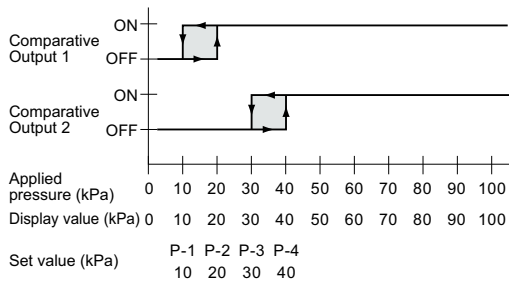

<With remote zero-adjustment input (comparative outputs set to NO)>

Remote zero-adjustment input: 50 kPa
Output mode: Hysteresis mode

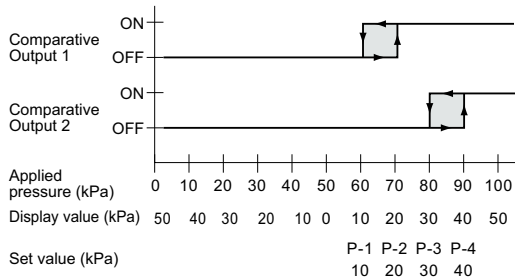

Note: As in the case of the hysteresis mode, the displayed values and the ON / OFF points of the output are shifted also in case the output mode is set to the window comparator mode.

Remote zero-adjustment input: 50 kPa
Output mode: Leak test mode

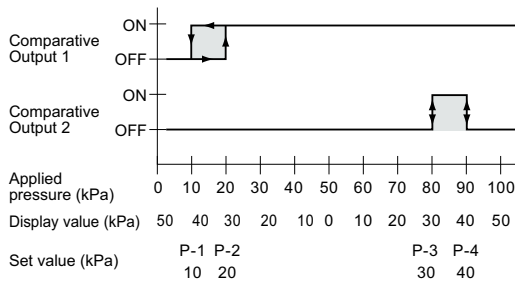

Note: In the leak test mode, the zero-adjustment function is applied only to Comparative Output 2. Comparative Output 1 operates with the atmospheric pressure as the reference.

- Maintain the pressure at a constant level for at least 2 ms after the remote zero-adjustment input is made Low (High in case of PNP output type). If used in a transient state, it will result in wrong operation.
- Use the comparative outputs at least "set response time + 2 ms" after the remote zero-adjustment input is made Low (High in case of PNP output type).
- At the time of remote zero-adjustment input, is displayed on the 3 1/2 digit display for 1 sec. approx.
- If the power supply is switched off and then on again, the remote zero-adjustment input value (set Value P-A) is cleared and the sensor returns to normal operation with atmospheric pressure as the reference.

Forced output mode

- In the initial setting mode, if the output mode is set to the forced output mode () , the comparative outputs are forcibly maintained at OFF level in the sensing mode, irrespective of Set Values P-1 to P-4. Further, if the keys are operated as per the procedure given below, the comparative outputs can be forcibly switched either ON or OFF without applying pressure at the pressure port. This is convenient for an operation check of the comparative outputs or for an inspection before commencing work.

Peak hold & bottom hold functions

- Peak hold and bottom hold functions enable the display of the peak value (maximum pressure value) and the bottom value (minimum pressure value) of the varying measured pressure. These functions are convenient for finding the pressure variation range or determining the reference for pressure settings.

• Please note that the peak value and the bottom value data is erased when it is no longer displayed.

Others

- Use within the rated pressure range.
- Do not apply pressure exceeding the pressure withstandability value. The diaphragm will get damaged and correct operation shall not be maintained.
- Do not use during the initial transient time (DP5: 3 sec. approx., DPH: 50 ms approx.) after the power supply is switched on.
- Avoid dust, dirt, and steam.
- Take care that the sensor does not come in direct contact with water, oil, grease, or organic solvents, such as, thinner, etc.
- Do not insert wires, etc., into the pressure port. The diaphragm will get damaged and correct operation shall not be maintained.
- Do not operate the keys with pointed or sharp objects.

FIBER SENSORS

LASER SENSORS

PHOTO-ELECTRIC SENSORS

MICRO PHOTO-ELECTRIC SENSORS

AREA SENSORS

SAFETY COMPONENTS

PRESSURE SENSORS

INDUCTIVE PROXIMITY SENSORS

PARTICULAR USE SENSORS

SENSOR OPTIONS

WIRE-SAVING SYSTEMS

MEASUREMENT SENSORS

STATIC CONTROL DEVICES

LASER MARKERS

Selection Guide

Flow

FM-200

Digital Display

DP-100

DP4

DP-M

Head-separated

DPH-100

DPC-100

DP5 / DPH

Other Products

PRECAUTIONS FOR PROPER USE

Refer to p.952 for general precautions.

Key-protect function

- Key-protect is a function which prevents any unintentional change in the conditions which have been entered in each setting mode by making the sensor not to respond to the key operations.

- Since the key-protect information is stored in an EEPROM, it is not erased even if the power supply is switched off.
- Please take care to remember if the key-protect function has been set.
- When the keys are to be operated, make sure that key-protect is released.

Piping

- When connecting a commercial coupling to the pressure port, hold the hexagonal section of the pressure port with a 11 mm 0.433 in (DPH-A1□, DPH-A2□: 12 mm 0.472 in) spanner, and make sure that the tightening torque is 1 N·m (male thread type of DPH-A1□, DPH-A2□: 5 N·m) or less. If excessive tightening torque is applied, the M5 male thread of the commercial coupling or the pressure port will get damaged.

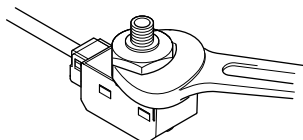

Connecting

- To connect the sensor head to the controller, the optional intermediate cable (DPH-CC□) must be used.
- Take care that stress is not directly applied to the cable joint or the connector.
- If the sensor head is to be mounted on a movable part, make sure to use a flexible intermediate cable.
- When connecting the intermediate cable to the controller, make sure to fit the connector cap, supplied as an accessory with the controller, by sliding it as shown in the figure below. If the connector cap is not fitted, there is a danger of the intermediate cable getting disconnected from the sensor.

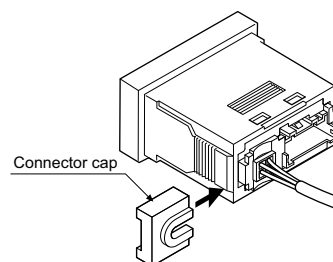

Mounting

- Install the enclosed panel mounting bracket (MS-DP-1) as shown in the figure below. The tightening torque should be 0.15 N·m or less. Further, tighten both the right and the left screw gradually and equally, so that the panel mounting bracket does not tilt.

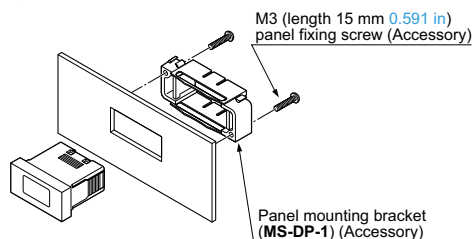

DIMENSIONS (Unit: mm in) The CAD data in the dimensions can be downloaded from the SUNX website: <http://www.sunx.com>

DP5-C DP5-C-P **Controller**

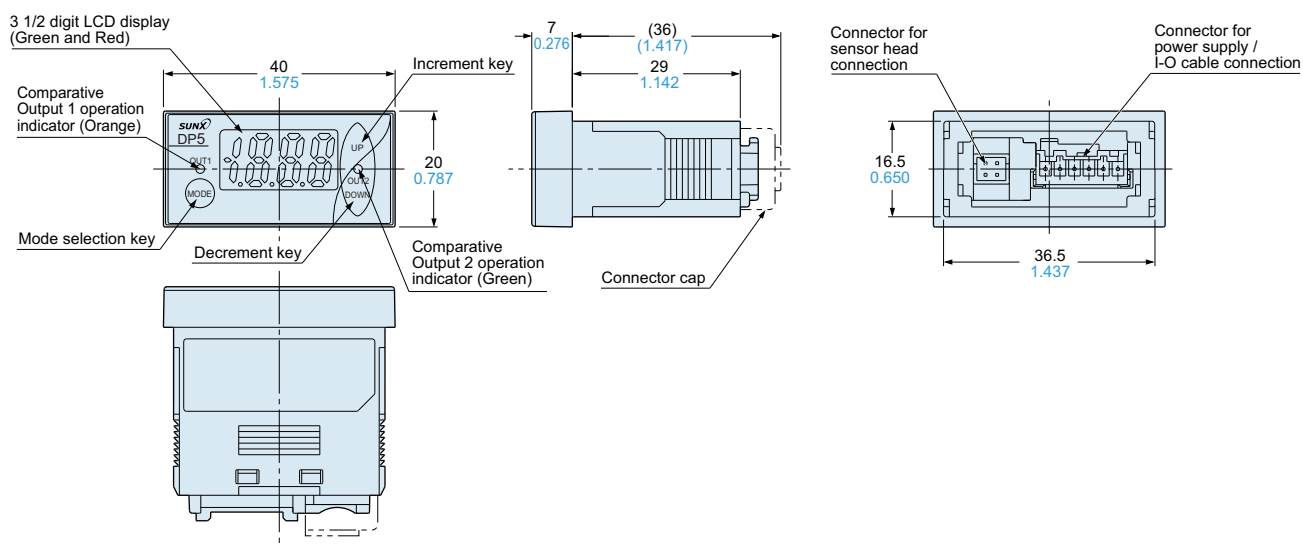

- FIBER SENSORS
- LASER SENSORS
- PHOTO-ELECTRIC SENSORS
- MICRO PHOTO-ELECTRIC SENSORS
- AREA SENSORS
- SAFETY COMPONENTS
- PRESSURE SENSORS**
- INDUCTIVE PROXIMITY SENSORS
- PARTICULAR USE SENSORS
- SENSOR OPTIONS
- WIRE-SAVING SYSTEMS
- MEASUREMENT SENSORS
- STATIC CONTROL DEVICES
- LASER MARKERS

- Selection Guide
- Flow
- FM-200**
- Digital Display
- DP-100**
- DP4**
- DP-M**
- Head-separated
- DPH-100 DPC-100**
- DP5 / DPH**
- Other Products

DIMENSIONS (Unit: mm in)

The CAD data in the dimensions can be downloaded from the SUNX website: <http://www.sunx.com>

DPH-A0 □ DPH-A30 □ Sensor head

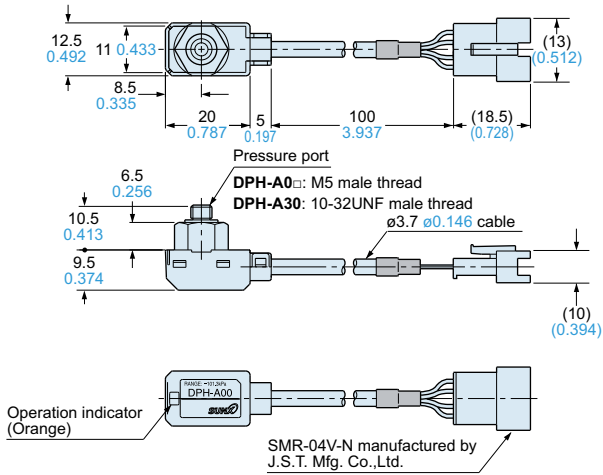

DPH-A1 □ DPH-A2 □ Sensor head

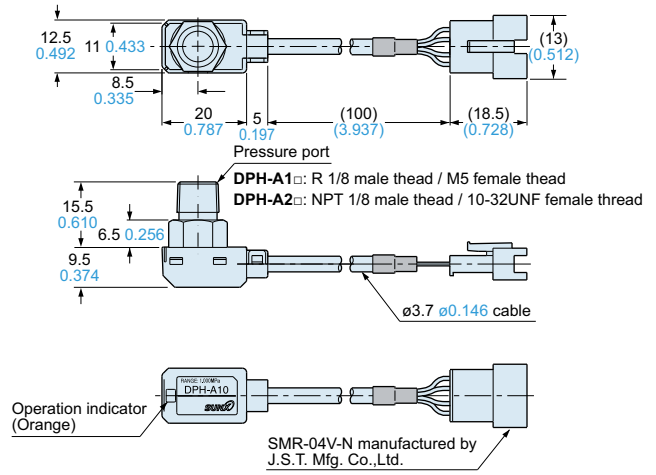

MS-DP-1

Panel mounting bracket (Accessory for the controller)

Assembly dimensions

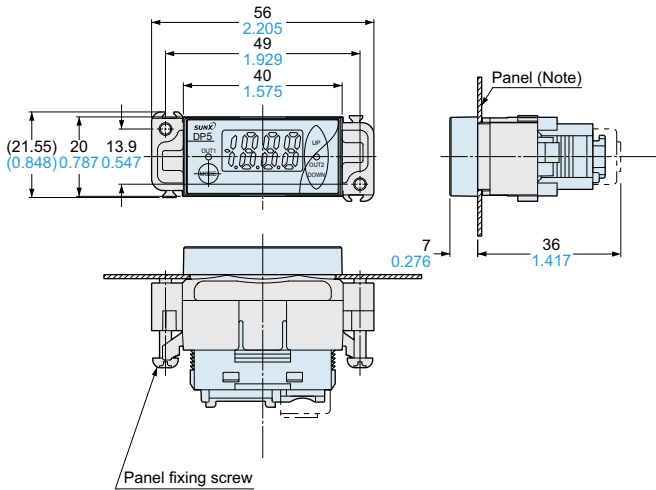

Panel cut-out dimensions

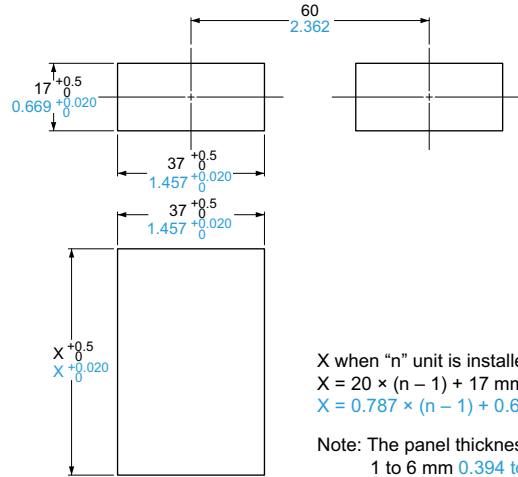

MS-DP-2

DIN rail mounting bracket (Optional)

Assembly dimensions

Vertical mounting

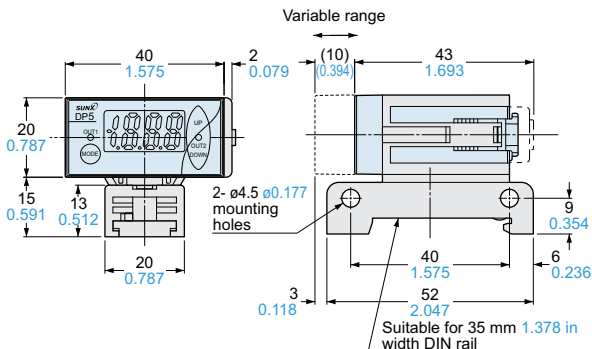

Horizontal mounting

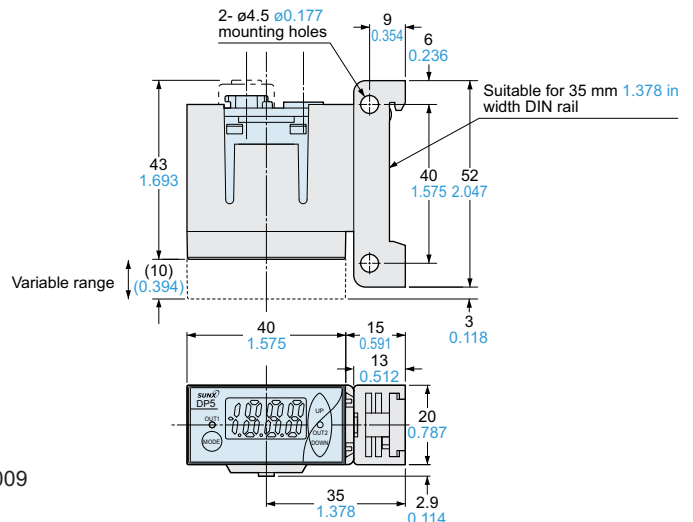

FIBER SENSORS
 LASER SENSORS
 PHOTO-ELECTRIC SENSORS
 MICRO PHOTO-ELECTRIC SENSORS
 AREA SENSORS
 SAFETY COMPONENTS
 PRESSURE SENSORS
 INDUCTIVE PROXIMITY SENSORS
 PARTICULAR USE SENSORS
 SENSOR OPTIONS
 WIRE- SAVING SYSTEMS
 MEASURE- MENT SENSORS
 STATIC CONTROL DEVICES
 LASER MARKERS
 Selection Guide
 Flow
FM-200
 Digital Display
DP-100
DP4
DP-M
 Head-separated
DPH-100
DPC-100
DP5 / DPH
 Other Products

DIMENSIONS (Unit: mm in) The CAD data in the dimensions can be downloaded from the SUNX website: <http://www.sunx.com>

DPH-CC

Intermediate cable (Optional)

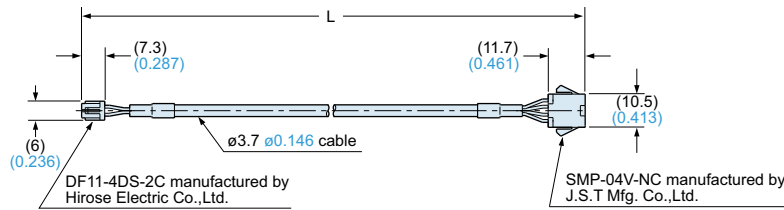

Note: The heat-shrink tube for the standard cable is black, and the heat-shrink tube for the flexible cable is gray.

• Length L

Model No.	Length L
DPH-CC2(-R)	2 m 6.562 ft
DPH-CC3(-R)	3 m 9.843 ft
DPH-CC5(-R)	5 m 16.404 ft

CN-66

Connector (Optional)

Housing

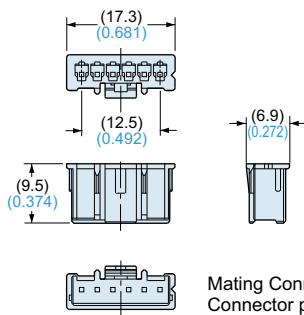

Mating Connector
Connector pin: BXA-001T-P0.6 manufactured by J.S.T. Mfg. Co., Ltd.
Housing: XAP-06V-01 manufactured by J.S.T. Mfg. Co., Ltd.
Crimping tool
YC-692R manufactured by J.S.T. Mfg. Co., Ltd.

CN-66-C2 CN-66-C5

Cable with connector (Optional)

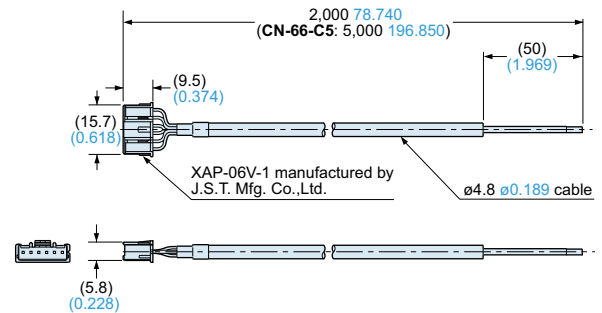

MS-DP-3

Controller mounting bracket (Optional)

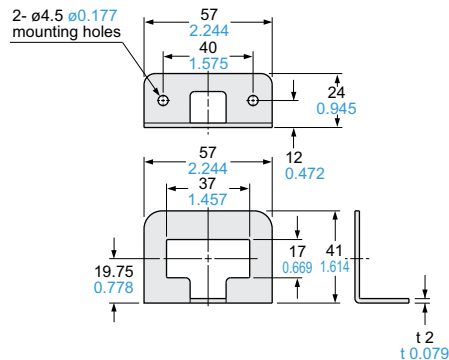

Material: Cold rolled carbon steel (SPCC)(Uni-chrome plated)
Note: Use together with panel mounting bracket (MS-DP-1) included with controller.

MS-DP-4

Controller mounting bracket (Optional)

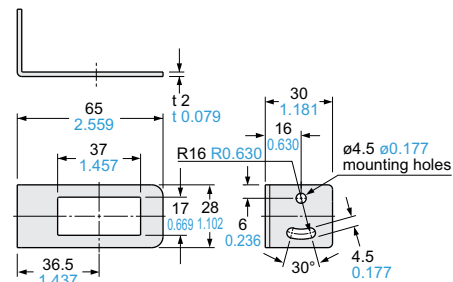

Material: Cold rolled carbon steel (SPCC)(Uni-chrome plated)
Note: Use together with panel mounting bracket (MS-DP-1) included with controller.

MS-DP-5

Horizontal multiple panel mounting bracket (Optional)

Assembly dimensions

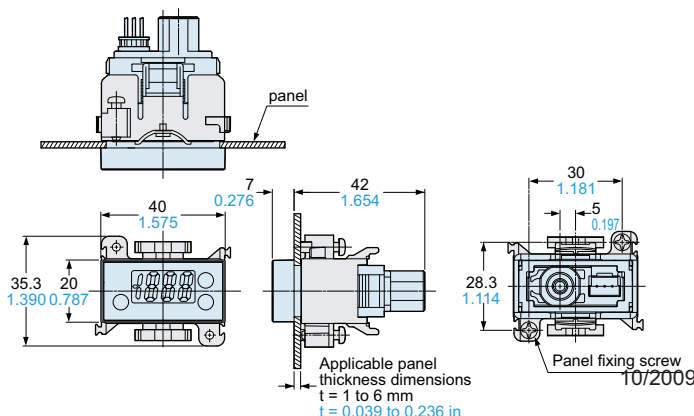

Panel cut-out dimensions

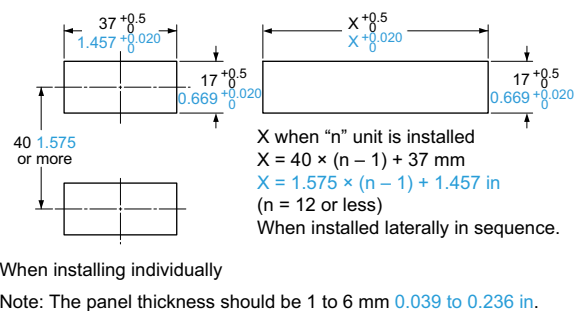

FIBER SENSORS
LASER SENSORS
PHOTO-ELECTRIC SENSORS
MICRO PHOTO-ELECTRIC SENSORS
AREA SENSORS
SAFETY COMPONENTS
PRESSURE SENSORS
INDUCTIVE PROXIMITY SENSORS
PARTICULAR USE SENSORS
SENSOR OPTIONS
WIRE-SAVING SYSTEMS
MEASUREMENT SENSORS
STATIC CONTROL DEVICES
LASER MARKERS
Selection Guide
Flow
FM-200
Digital Display
DP-100
DP4
DP-M
Head-separated
DPH-100
DPC-100
DP5 / DPH
Other Products