

DP-Y SERIES

LED Display Anti-corrosive Digital Pressure Sensor



Pressure Measurement of Corrosive Gases and Liquids Possible

CE Marked
Conforming to EMC Directive

Superior Anti-corrosive Hastelloy C Diaphragm and Stainless Steel SUS316 Pressure Port

It can be used in equipment which handles not only water and oil, but also, various gases and liquids which do not corrode Hastelloy C and stainless steel SUS316.

It can be used in semiconductor manufacturing equipment, automatic assembly machines, machine tools, injection molding machines, construction equipment, automobile inspection machines, etc.

Construction diagram

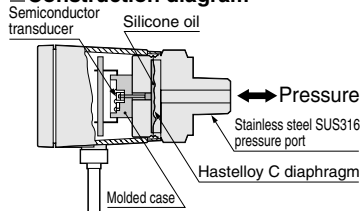

Hastelloy C diaphragm

Hastelloy C is a high molybdenum content nickel alloy having excellent anti-corrosive properties. Especially, since the diaphragm is very thin, Hastelloy C diaphragm which has superior anti-corrosive properties has been used instead of a stainless steel diaphragm.

Compound Pressure Type Available

Compound pressure type **DP-Y27(E)**, which can measure from vacuum pressure to positive pressure, is available.

Pressure from -98.6kPa (2.7kPa abs) to 100.0kPa can be monitored.

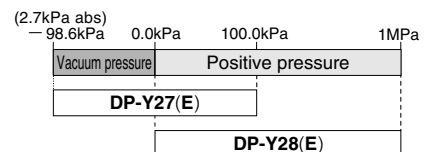

Bright & Clearly Visible LED Display

Bright and clearly visible 3 1/2 digit red LEDs, having 10mm letter height, have been incorporated. The display can be easily read not only in a dark place, but also, in a well-lit place.

High Resolution of 1/1,000

Minute measurement is easily done with a high resolution of 1/1,000.

Analog Voltage Output Incorporated as a Standard

Since a linear analog voltage output (1 to 5V) is incorporated, the sensor is ideally suited for real time monitoring or for remote control in combination with an analog controller (digital panel controller **CA2** series).



CA2 series

Digital panel controller

Simple Operation

Initial setting or pressure value setting can be easily done by key operation while seeing the display.



APPLICATIONS

Confirmation of suction of glass sheets

The sensor can be safely used even if moisture is present during suction, since the superior anti-corrosive Hastelloy C diaphragm has been employed.

Further, if the compound pressure type **DP-Y27(E)** is used, it is safe even if a reverse pressure is generated when the glass sheet is released.

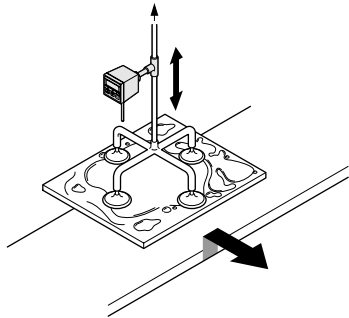

Pressure control in semiconductor manufacturing equipment

By using the compound pressure type **DP-Y27(E)**, pressure control inside a semiconductor manufacturing equipment is possible and the vacuum pressure, as well as, the purge pressure can be measured from negative to positive pressure values.

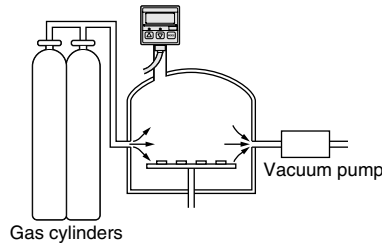

Pressure measurement of corrosive gas

Since it is anti-corrosive, it can be used in equipment handling corrosive gas.

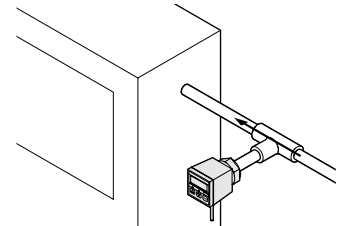

Analog Bar Display

Pressure changes can also be displayed in an analog fashion using LED bars. Hence, sudden pressure changes can be recognized at a glance.

LED bars indicate the pressure level in steps of 10% F.S. [**DP-Y27(E)**: steps of 5% F.S.], regardless of the pressure unit.

Analog bar display

Digital display

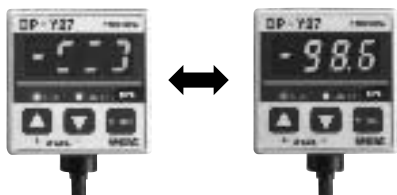

Peak Hold/Bottom Hold Display

The peak value or the bottom value of the varying pressure can be displayed. This function is convenient for finding the pressure variation range or for determining a reference for pressure settings.

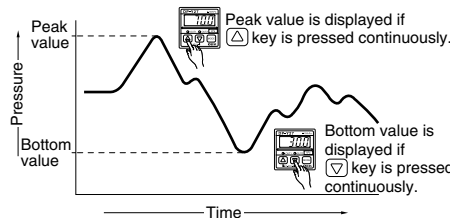

Selection from Five Pressure Units

The pressure unit can be selected from five different systems [**DP-Y28(E)**: four systems] to suit your requirement.

The pressure units which can be selected for **DP-Y27(E)** and **DP-Y28(E)** differ. When the pressure unit is changed, the measured pressure value and the set values are automatically converted.

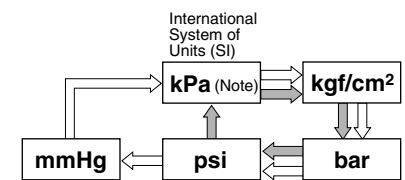

→ : Compound pressure type **DP-Y27(E)**
 ⇄ : Positive pressure type **DP-Y28(E)**
 Note: 'MPa' in case of **DP-Y28(E)**

Two Outputs with Four Independent Settings and Three Output Modes Enable Control as per Your Requirement

1 Hysteresis mode

The hysteresis of the comparative outputs can be set, as desired, with the set values.

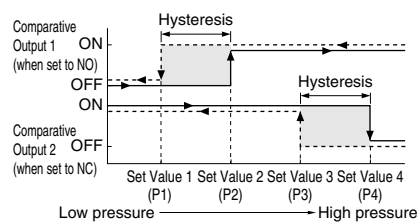

2 Window comparator mode

The comparative outputs can be turned ON or OFF by a pressure within the set range.

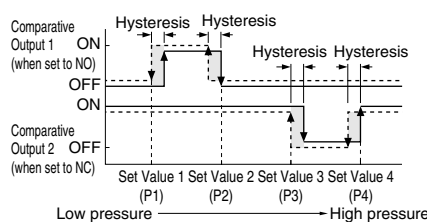

3 Forced output mode

The comparative outputs are forcibly maintained in the OFF state in the sensing mode, irrespective of the set values.

Also, since the comparative outputs can be forcibly made ON or OFF with key operation, without actually applying pressure, this mode is suitable for an operation check or a start-up check.

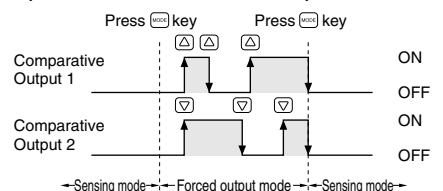

Useful for suction related applications

Useful for confirming reference pressure, etc.

Useful for operation, or start-up, check

DP-Y

ORDER GUIDE

Type		Appearance	Rated pressure range (Note)	Model No.	Pressure port	Comparative output
Compound pressure	± 100kPa type		- 98.6kPa (2.7kPa abs) to 100.0kPa	DP-Y27	R (PT) 1/4 male thread and M5 female thread	NPN open-collector transistor
	PNP output			DP-Y27E		PNP open-collector transistor
Positive pressure	1MPa type		0 to 1.000MPa	DP-Y28		NPN open-collector transistor
	PNP output			DP-Y28E		PNP open-collector transistor

Note: The rated pressure range is the range over which the product specifications are satisfied.

OPTIONS

Designation	Model No.	Description	
Sensor mounting bracket	MS-DPY-1	It is a sensor mounting bracket. (Two tap-tight screws are attached.)	
Panel mounting bracket	MS-DPY-2	It can be used for mounting on a panel (1 to 3.2mm thick). (Two tap-tight screws and two M3 fixing screws are attached.)	
Front protection cover	MS-PE-3	It protects the sensor's adjustment panel. (It can be fitted when the panel mounting bracket is used.)	
Digital panel controller	CA2-T2	NPN open-collector transistor	<p>This is a very small controller which allows two independent threshold level settings.</p> <ul style="list-style-type: none"> • Supply voltage: 24V DC ± 10% • No. of inputs: 1 No. (sensor input) • Input range: 1 to 5V DC • Main functions: Threshold level setting function, zero-adjust function, scale setting function, hysteresis setting function, start/hold function, auto-reference function, power supply ON-delay function, etc.

Sensor mounting bracket

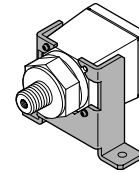

Two tap-tight screws are attached.

Panel mounting bracket, Front protection cover

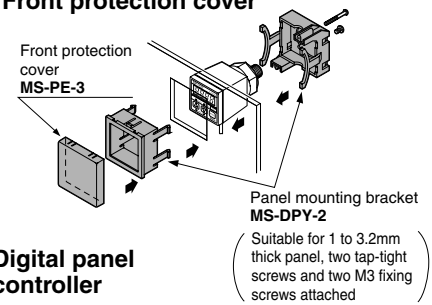

Digital panel controller

• CA2 series



SPECIFICATIONS

Type		Compound pressure		Positive pressure	
		± 100kPa type		1MPa type	
		NPN output	PNP output	NPN output	PNP output
Item	Model No.	DP-Y27	DP-Y27E	DP-Y28	DP-Y28E
Type of pressure		Gauge pressure			
Rated pressure range (Note 1)		- 98.6kPa (2.7kPa abs) to 100.0kPa		0 to 1.000MPa	
Set pressure range (Note 2)		$\left\{ \begin{array}{l} - 101.2 \text{ to } 110.0\text{kPa} \\ - 1.032 \text{ to } 1.122\text{kgf/cm}^2, - 1.012 \text{ to } 1.100\text{bar} \\ - 14.68 \text{ to } 15.96\text{psi}, - 760 \text{ to } 826\text{mmHg} \end{array} \right\}$		$\left\{ \begin{array}{l} - 0.050 \text{ to } 1.050\text{MPa} \\ - 0.50 \text{ to } 10.70\text{kgf/cm}^2, - 0.50 \text{ to } 10.50\text{bar} \\ - 7.2 \text{ to } 152.2\text{psi} \end{array} \right\}$	
Set pressure resolution		0.2kPa {0.002kgf/cm ² , 0.002bar, 0.02psi, 2mmHg}		0.001MPa {0.01kgf/cm ² , 0.01bar, 0.1psi}	
Pressure withstandability		- 98.6kPa (2.7kPa abs) to 200kPa		- 98.6kPa (2.7kPa abs) to 2MPa	
Applicable fluid		Gas or liquid which does not corrode stainless steel SUS316 and Hastelloy C			
Selectable units		kPa, kgf/cm ² , bar, psi, mmHg		MPa, kgf/cm ² , bar, psi	
Supply voltage		12 to 24V DC $^{+10}_{-15}$ % Ripple P-P 10% or less			
Current consumption		50mA or less			
Comparative outputs (Comparative Output 1 Comparative Output 2)		<NPN output type> NPN open-collector transistor • Maximum sink current: 100mA • Applied voltage: 30V DC or less (between comparative output and 0V) • Residual voltage: 1V or less (at 100mA sink current)		<PNP output type> PNP open-collector transistor • Maximum source current: 100mA • Applied voltage: within supply voltage range (between comparative output and + V) • Residual voltage: 2V or less (at 100mA source current)	
		Utilization category: DC-12 or DC-13			
Output modes		Equipped with 3 types of modes: hysteresis mode, window comparator mode, forced output mode (selectable by key operation)			
Hysteresis		1 digit or more when using hysteresis mode [DP-Y27(E): 2 digits or more], 1 digit when using window comparator mode [DP-Y27(E): 2 digits]			
Repeatability		Within ± 0.2% F.S. ± 2 digits		Within ± 0.2% F.S. ± 1 digit	
Response time		5ms or less			
Short-circuit protection		Incorporated			
Analog voltage output		Output voltage: 1 to 5V [DP-Y27(E): for - 100.0 to 100.0kPa] [DP-Y28(E): for 0 to 1.000MPa] Zero-point: within 1V ± 1% F.S. Span: within 4V ± 1% F.S. Linearity: within ± 1% F.S. Output impedance: 1kΩ approx.			
Display		3½ digit red LED display (Sampling rate: 4 times/sec. approx.)			
Displayable pressure range		Same as set pressure range			
Displayable resolution		Same as set pressure resolution			
Analog bar display		LED bar display in steps of 5% F.S. approx.		LED bar display in steps of 10% F.S. approx.	
Operation indicators	Comparative Output 1	Orange LED (lights up when Comparative Output 1 is ON)			
	Comparative Output 2	Green LED (lights up when Comparative Output 2 is ON)			
Environmental resistance	Pollution degree	3 (Industrial environment)			
	Protection	IP40 (IEC)			
	Ambient temperature	0 to + 50°C (No dew condensation or icing allowed), Storage: - 10 to + 60°C			
	Ambient humidity	35 to 85% RH, Storage: 5 to 95% RH			
	EMC	Emission: EN50081-2, Immunity: EN50082-2			
	Voltage withstandability	500V AC for one min. between all supply terminals connected together and polycarbonate enclosure			
	Insulation resistance	50MΩ, or more, with 500V DC megger between all supply terminals connected together and polycarbonate enclosure			
	Vibration resistance	10 to 150Hz frequency, 1.5mm amplitude, or 10G in X, Y and Z directions for two hours each			
Shock resistance	100m/s ² acceleration (10G approx.) in X, Y and Z directions for three times each				
Temperature characteristics		Over ambient temperature range 0 to + 50°C: within ± 3% F.S. of detected pressure at 25°C			
Pressure port		R (PT) ¼ male thread or M5 female thread			
Material		Enclosure: Polycarbonate, Diaphragm: Hastelloy C, Enclosed liquid: Silicone oil, Pressure port: Stainless steel (SUS316)			
Cable		0.2mm ² 5-core flame-retardant PVC cabtyre cable, 2m long			
Cable extension		Extension up to total 100m is possible with 0.3mm ² , or more, cable.			
Weight		240g approx.			
Accessory		Pressure unit label: 1 No.			

Notes: 1) The rated pressure range is the range over which the product specifications are satisfied.

2) The set pressure range is the range over which the pressure can be set and displayed.

DP-Y

I/O CIRCUIT AND WIRING DIAGRAMS

NPN output type

I/O circuit diagram

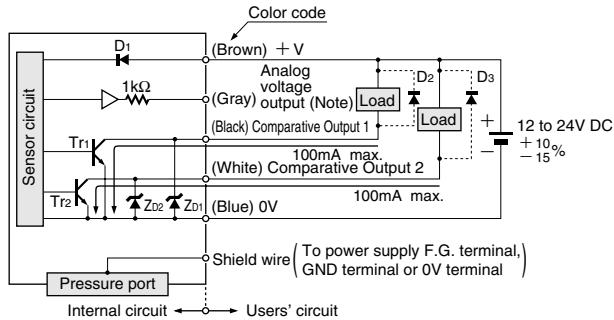

Note: When using the analog voltage output, take care to connect external equipment of proper input impedance. Also, when a cable extension is used, voltage drop due to cable resistance should be taken into account.

Symbols ... D1: Reverse supply polarity protection diode
 D2, D3: Inductive load surge protection diode
 ZD1, ZD2: Surge absorption zener diode
 Tr1, Tr2: NPN output transistor

Wiring diagram

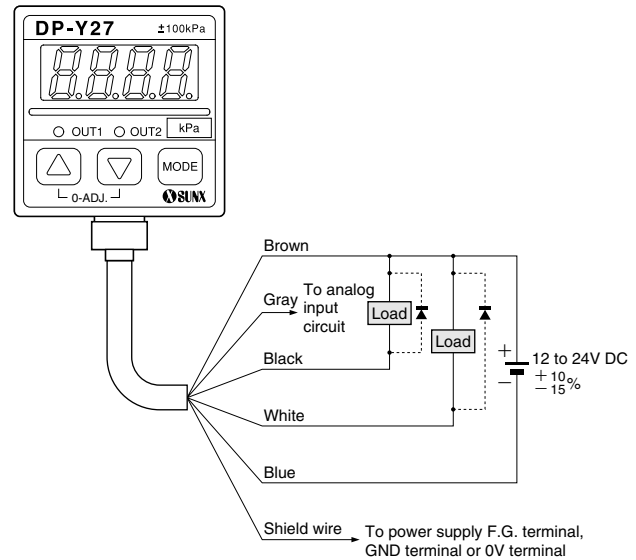

PNP output type

I/O circuit diagram

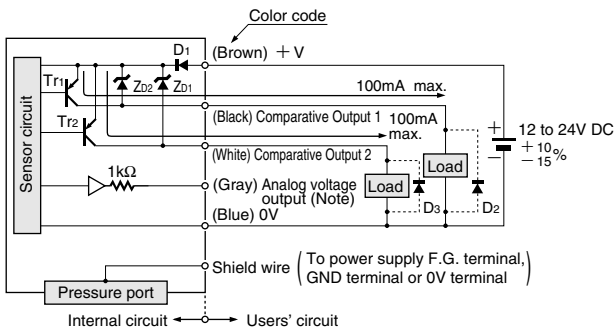

Note: When using the analog voltage output, take care to connect external equipment of proper input impedance. Also, when a cable extension is used, voltage drop due to cable resistance should be taken into account.

Symbols ... D1: Reverse supply polarity protection diode
 D2, D3: Inductive load surge protection diode
 ZD1, ZD2: Surge absorption zener diode
 Tr1, Tr2: PNP output transistor

Wiring diagram

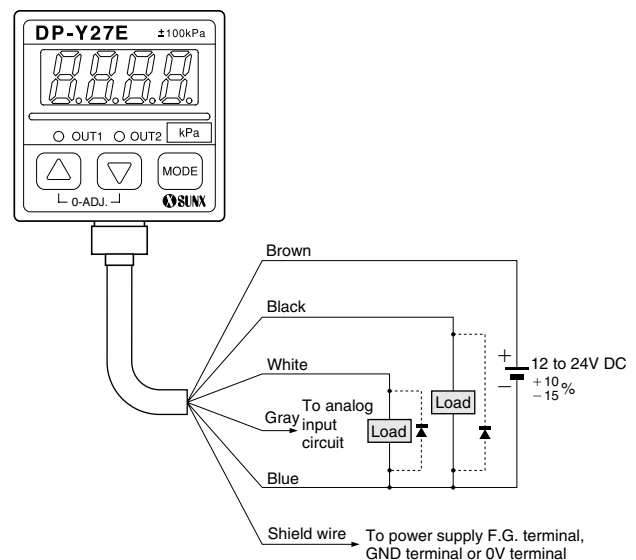

PRECAUTIONS FOR PROPER USE



This product is not a safety sensor. Its use is not intended or designed to protect life and prevent body injury or property damage from dangerous parts of machinery. It is a normal pressure detection sensor.

Piping

- When connecting a coupling to the pressure port, hold the hexagonal portion of the pressure port with a 30mm spanner and make sure that the tightening torque is as given below.

R (PT) 1/4 male thread: 39.2N·m or less
M5 female thread: 2N·m or less

(Do not hold the plastic body with a spanner.)

Also, in order to prevent any leakage, wind a sealing tape on the coupling when connecting.

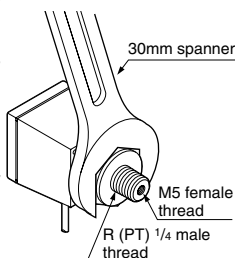

Mounting

- If the sensor is mounted on the optional sensor mounting bracket, make sure that the tightening torque is 0.2 N·m or less.

Nominal dia. 2.6 (length 6mm) tap-tight screw
(Attached with MS-DPY-1)

Sensor mounting bracket
MS-DPY-1 (Optional)

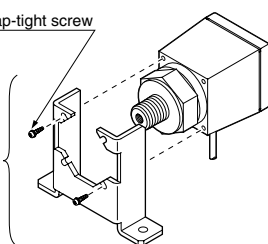

Wiring

- Make sure to carry out the wiring in the power supply off condition.
- Verify that the supply voltage variation is within the rating.
- Do not use a power supply having an auto-transformer (single winding transformer), as it is dangerous. Make sure to use a power supply having an isolation transformer.
- If power is supplied from a commercial switching regulator, ensure that the frame ground (F.G.) terminal of the power supply is connected to an actual ground.
- In case noise generating equipment (switching regulator, inverter motor, etc.) is used in the vicinity of this sensor, connect the frame ground (F.G.) terminal of the equipment to an actual ground.
- Connect the sensor shield wire to the power supply's frame ground (F.G.) terminal. In case the used power supply does not have a frame ground (F.G.) terminal, connect the sensor shield wire to the power supply's GND or 0V terminal. This results in direct earth (power supply's 0V directly connected to the pressure port) since the sensor shield wire is connected to the pressure port. However, in case the power supply's 0V must be isolated from the mounting stand or the piping, insulate the shield wire with a tape and keep it in the open state.
- Do not run the wires together with high-voltage lines or power lines or put them in the same raceway. This can cause malfunction due to induction.
- The analog voltage output is not incorporated with a short-circuit protection circuit. Do not directly connect a power supply or a capacitive load.

Functional description

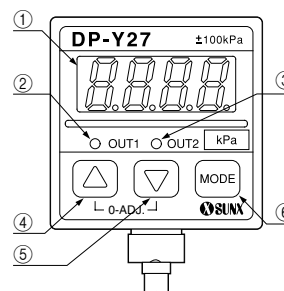

	Description	Function
①	3 1/2 digit LED display (Red)	Displays measured pressure, settings, error messages and key-protect status.
②	Comparative Output 1 operation indicator (Orange)	Lights up when Comparative Output 1 is ON.
③	Comparative Output 2 operation indicator (Green)	Lights up when Comparative Output 2 is ON.
④	Increment key (△)	<ul style="list-style-type: none"> In the initial setting mode or the output operation setting mode, pressing the key changes the settable digit. In the Set Value 1 to 4 modes, pressing the key changes the set value towards the high pressure side. In the sensing mode, if the key is pressed continuously for more than 4 sec., the display shows the peak hold value.
⑤	Decrement key (▽)	<ul style="list-style-type: none"> In the initial setting mode or the output operation setting mode, pressing the key changes the set conditions. In the Set Value 1 to 4 modes, pressing the key changes the set value towards the low pressure side. In the sensing mode, if the key is pressed continuously for more than 4 sec., the display shows the bottom hold value.
⑥	Mode selection key (MODE)	<ul style="list-style-type: none"> Pressing the key changes the selected mode to sensing mode, Set Value 1 to 4 setting modes and output operation setting mode. In the sensing mode, if the key is pressed continuously for about 3 sec., key-protect can be set/released. In the sensing mode, if the mode selection key is pressed while the increment key (△), the initial setting mode is obtained.

In the sensing mode, if both the keys are pressed simultaneously, zero-point adjustment is done.

Error messages

- When an error occurs, take the following corrective action.

Error message	Cause	Corrective action
E-11	Overcurrent due to Comparative Output 1 load short-circuit.	Switch off the power supply and check the load.
E-12	Overcurrent due to Comparative Output 2 load short-circuit.	
E-3	Pressure is being applied during zero-point adjustment.	Applied pressure at the pressure port should be brought to atmospheric pressure and zero-point adjustment should be done again.
- - -	Applied pressure exceeds the upper limit of displayable pressure range.	Applied pressure should be brought within the rated pressure range.
- - - -	Applied pressure exceeds the lower limit of displayable pressure range.	

DP-Y

PRECAUTIONS FOR PROPER USE

Setting

- If key-protect has been set, make sure to release key-protect before operating the keys.
(Please refer to 'Key-protect function' 731 for the procedure.)
- Set Value 1 to 4 (P1 to P4) can be used in common for all the output modes.
- Setting can be done only as follows: Set Value 1 (P1) < Set Value 2 (P2), Set Value 3 (P3) < Set Value 4 (P4).
- The conditions which are set are stored in an EEPROM. Kindly note that the EEPROM has a life span and its guaranteed life is 10,000 write operation cycles.

Setting procedure

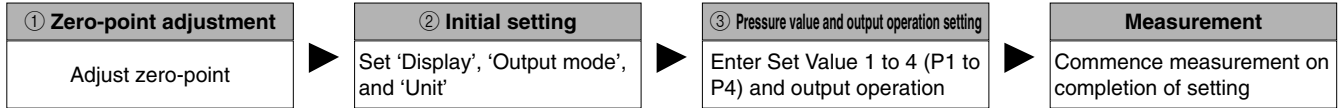

① Zero-point adjustment

- The displayed pressure when the pressure port is left open is adjusted to zero.

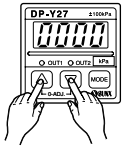

- The sensor will automatically enter the sensing mode when power is supplied.
- Let the pressure port be at atmospheric pressure (i.e., no applied pressure condition), and press, simultaneously, Δ and ∇ keys continuously.
- 0.000 is displayed and, when the fingers are released, zero-point adjustment is completed and the sensor returns to the sensing mode.

② Initial setting

- Pressure 'Unit', 'Display' and 'Output mode' of the comparative outputs are set.

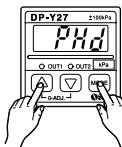

- In the sensing mode, press MODE key while pressing Δ key.
- Initial setting is displayed.
- If sensor is being used for the first time, PHd is displayed.)
- The settable digit blinks.
- The settable digit changes when Δ key is pressed.
- The setting changes when ∇ key is pressed.
- After the setting, press MODE key to return to the sensing mode.

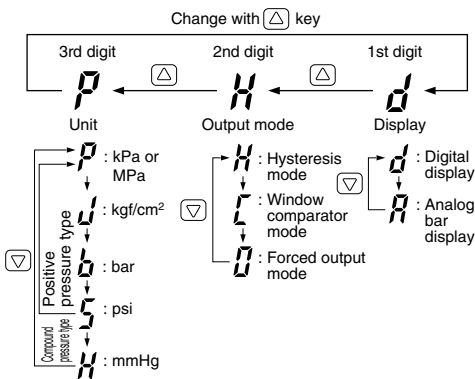

- When operated in window comparator mode (L) Set Value 1 (P1) and Set Value 2 (P2), or Set Value 3 (P3) and Set Value 4 (P4), will be automatically set with a difference of 6 digits, or more, in case of DP-Y27(E) and with a difference of 3 digits, or more, in case of DP-Y28(E).

③ Pressure value and output operation setting

- Set Value 1 to 4 (P1 to P4) of the comparative outputs and output operation are set.

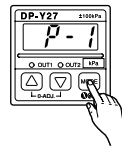

- At each press of MODE key, the mode changes, in rotation, to Set Value 1 (P1) set mode, Set Value 2 (P2) set mode, Set Value 3 (P3) set mode, Set Value 4 (P4) set mode, output operation set mode and sensing mode.

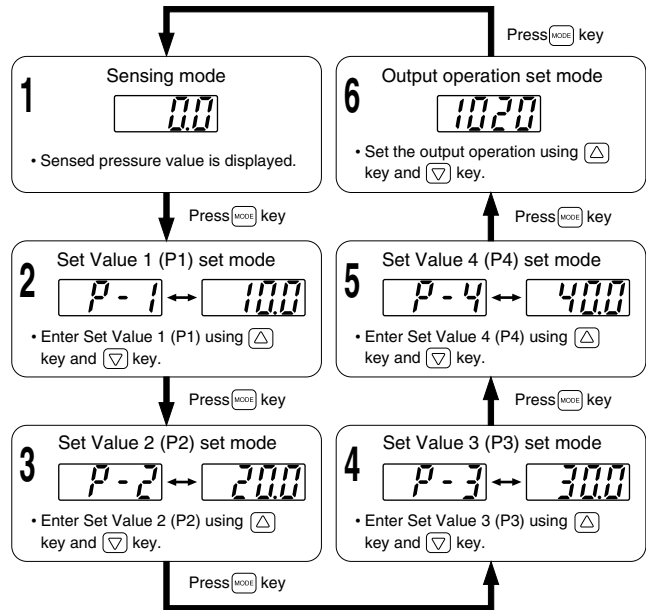

<Setting of output operation>

- Output operation of Comparative Output 1, 2 is, respectively, set to either normally open (NO) or normally closed (NC).
- When MODE key is pressed in the Set Value 4 (P4) set mode, the sensor enters output operation setting mode and the setting of output operation is displayed.
- 1020 is displayed when the sensor is used for the first time.)
- The settable digit blinks.
- Whenever Δ key is pressed, the settable digit changes, and whenever ∇ key is pressed the setting changes.
- After the setting, press MODE key to return to the sensing mode.

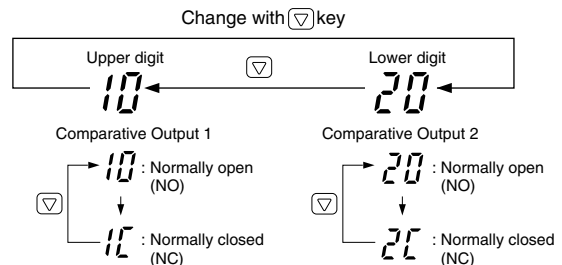

PRECAUTIONS FOR PROPER USE

Peak hold & bottom hold functions

- Peak hold and bottom hold functions enable the display of the peak value (maximum pressure value) and the bottom value (minimum pressure value) of the varying measured pressure. These functions are convenient for finding the pressure variation range or for determining the reference for pressure settings.

Please note that the peak value and the bottom value data is erased when it is no longer displayed.

Peak hold display

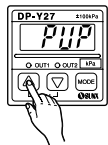

- In the sensing mode, keep Δ key pressed until PUP is displayed. (4 sec. approx.)
- When the finger is released after PUP is displayed, the peak value and PUP are displayed alternately.
- If the applied pressure exceeds the displayable pressure range, error message (---) or (---) and PUP are displayed alternately. In this case, bring back the applied pressure to within the rated pressure range.
- The figure on the left shows the display of DP-Y27(E) when the pressure unit has been set to 'kPa' (P) and the display to 'digital display' (d).
- In the end, press Δ key.
 - Sensor returns to sensing mode.]

Displayed alternately



Bottom hold display

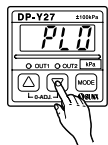

- In the sensing mode, keep ∇ key pressed until PLW is displayed. (4 sec. approx.)
- When the finger is released after PLW is displayed, the bottom value and PLW are displayed alternately.
- If the applied pressure exceeds the displayable pressure range, error message (---) or (---) and PLW are displayed alternately. In this case, bring back the applied pressure to within the rated pressure range.
- The figure on the left shows the display of DP-Y27(E) when the pressure unit has been set to 'kPa' (P) and the display to 'digital display' (d).
- In the end, press ∇ key.
 - Sensor returns to sensing mode.]

Displayed alternately



Key-protect function

- Key-protect is a function which prevents any unintentional change in the conditions which have been entered in each setting mode by making the sensor not to respond to the key operations.

Setting of key-protect

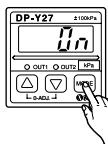

- In the sensing mode, press \square key continuously for about 3 sec. and release it immediately when Kn is displayed.
- Key-protect is set and the sensor returns to the sensing mode.
- Since the key-protect information is stored in an EEPROM, it is not erased even if the power supply is switched off.
- Please take care to remember if key-protect has been set.

Release of key-protect



- In the sensing mode, press \square key continuously for about 3 sec. and release it immediately when OFF is displayed.
- Key-protect is released and the sensor returns to the sensing mode.
- When the keys are to be operated, make sure that key-protect is released.

Forced output mode

- In the initial setting, if the output mode is set to the forced output mode (∇), Comparative Output 1, 2 are forcibly maintained at OFF level in the sensing mode, irrespective of Set Value 1 to 4 (P1 to P4). Hence, this mode is useful when it is desired to only display the pressure value without using the comparative outputs. Further, if the keys are operated as per the procedure given below, Comparative Output 1, 2 can be forcibly switched either ON or OFF without applying pressure at the pressure port. This is convenient for an operation check of Comparative Output 1, 2 or for an inspection before commencing work.

(The figure below is for DP-Y27(E) with the unit set to 'kPa' (P) and the display to 'digital display' (d).)

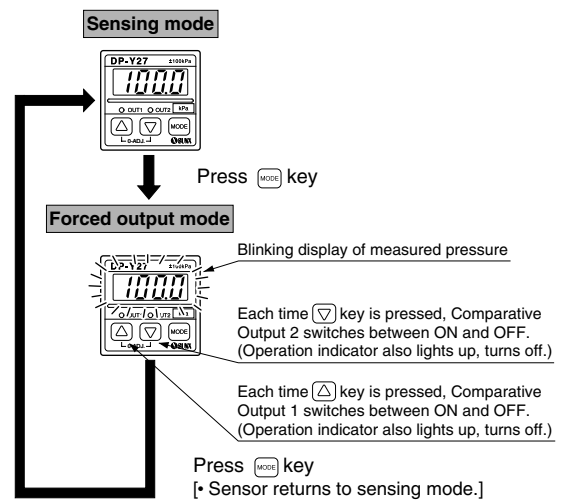

Time chart

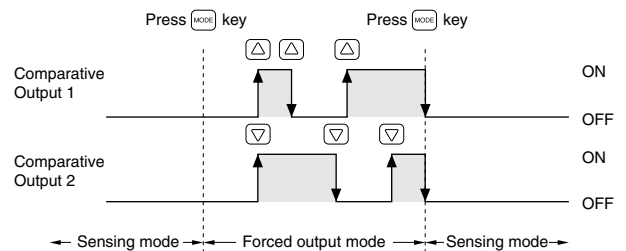

- The comparative outputs are held at the OFF level from the time a change is made to the forced output mode (∇) from the other modes.
- Even if a comparative output is held at the ON level in the forced output mode, it is forcibly brought to the OFF level at the time the sensor returns to the sensing mode.

DP-Y

PRECAUTIONS FOR PROPER USE

Conversion of pressure units

- In the DP-Y series, the conversion to different units is automatically done on changing the setting of the pressure unit. However, this conversion can also be obtained by multiplying the values by the coefficients given in the table on the right.

Conversion procedure

- For example, if 2kPa is to be expressed in kgf/cm², since 1kPa = 1.01972 × 10⁻²kgf/cm², 2kPa becomes 2 × 1.01972 × 10⁻² ≐ 0.020kgf/cm².

Conversion table for pressure units

	kPa	MPa	kgf/cm ²	bar	psi	mmHg (Torr)	inHg	atm
1kPa	1	1 × 10 ⁻³	1.01972 × 10 ⁻²	1 × 10 ⁻²	1.45038 × 10 ⁻¹	7.50062	0.2953	9.86923 × 10 ⁻³
1MPa	1 × 10 ³	1	1.01972 × 10	1 × 10	1.45038 × 10 ²	7.50062 × 10 ³	0.2953 × 10 ³	9.86923
1kgf/cm ²	9.80665 × 10	9.80665 × 10 ⁻²	1	9.80665 × 10 ⁻¹	1.42234 × 10	7.35559 × 10 ²	2.8959 × 10	9.67841 × 10 ⁻¹
1bar	1 × 10 ²	1 × 10 ⁻¹	1.01972	1	1.45038 × 10	7.50062 × 10 ²	2.953 × 10	9.86923 × 10 ⁻¹
1psi	6.89473	6.89473 × 10 ⁻³	7.03065 × 10 ⁻²	6.89473 × 10 ⁻²	1	5.17147 × 10	2.036	6.80457 × 10 ⁻²
1mmHg (1Torr)	1.33322 × 10 ⁻¹	1.33322 × 10 ⁻⁴	1.35951 × 10 ⁻³	1.33322 × 10 ⁻³	1.93368 × 10 ⁻²	1	3.9370 × 10 ⁻²	1.31579 × 10 ⁻³
1inHg	3.3864	3.3864 × 10 ⁻³	3.4531 × 10 ⁻²	3.3864 × 10 ⁻²	0.4912	2.5400 × 10	1	3.342 × 10 ⁻²
1atm	1.01325 × 10 ²	1.01325 × 10 ⁻¹	1.03323	1.01325	1.46960 × 10	7.60000 × 10 ²	2.9921 × 10	1

Label for change in pressure unit

- When a pressure unit other than 'kPa' (P) or 'MPa' (P) has been selected in the initial setting mode, the label (supplied as accessory) which corresponds to the selected unit should be stuck at the position shown in the figure below.

Pressure unit label (accessory)

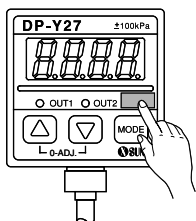
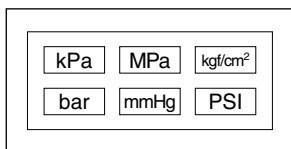

Stick the pressure unit label at the position shown.

Others

- Use within the rated pressure range.
- Do not apply pressure exceeding the pressure with-standability value. The diaphragm will get damaged and correct operation shall not be maintained.
- Do not use during the initial transient time (0.5 sec.) after the power supply is switched on.
- Avoid dust, dirt, and steam.
- Take care that the sensor does not come in direct contact with water, oil, grease, or organic solvents, such as, thinner, etc.
- Do not insert wires, etc., into the pressure port. The diaphragm will get damaged and correct operation shall not be maintained.
- Do not operate the keys with pointed or sharp objects.

DIMENSIONS (Unit: mm)

DP-Y27 DP-Y27E DP-Y28 DP-Y28E Sensor

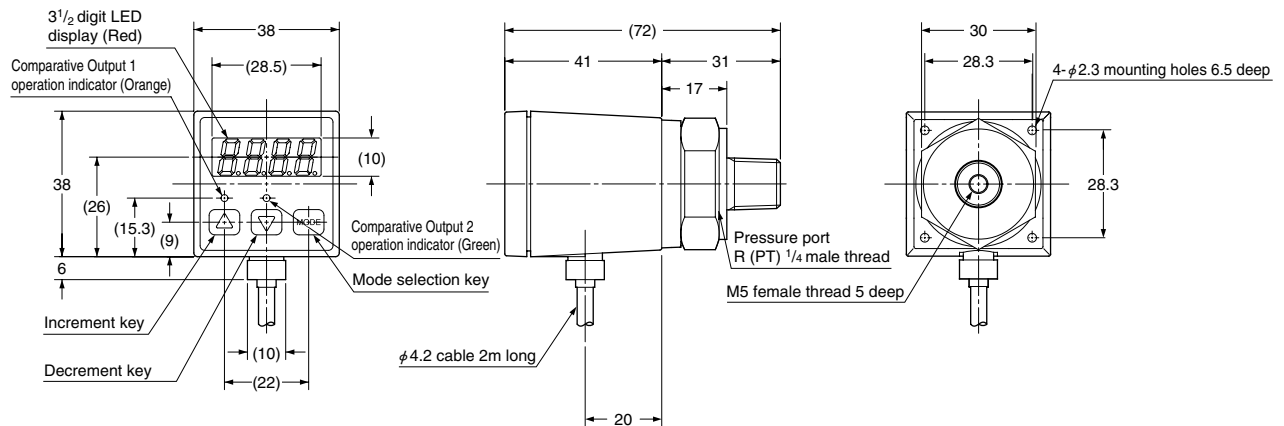

MS-DPY-1 Sensor mounting bracket (Optional)

Assembly dimensions

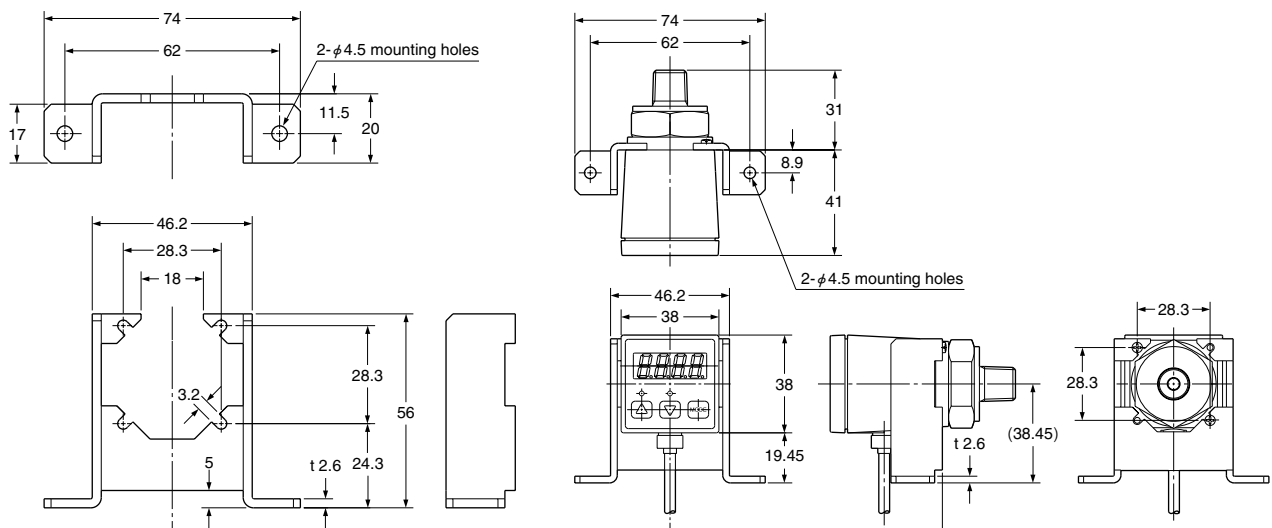

Material: Cold rolled carbon steel (SPCC)
(Zinc plated)

Two nominal dia. 2.6 (length 6mm) tap-tight screws are attached.

MS-PE-3 MS-DPY-2 Panel mounting bracket, front protection cover (Optional)

Assembly dimensions

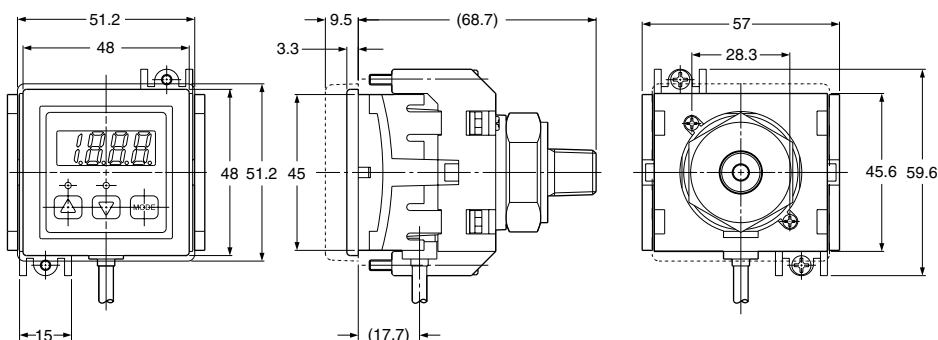

Panel cut-out dimensions

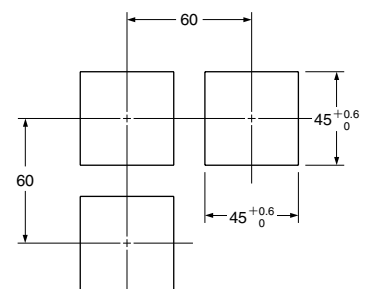

Note: The panel thickness should be 1 to 3.2mm.

□ portion shows the front protection cover.

Material: Polycarbonate (Front protection cover)
Polypropylene (Panel mounting bracket)

Two nominal dia. 2.6 (length 5mm) tap-tight screws, and two M3 (length 30mm) fixing screws are attached.